

Fixed V-groove Fusion Splicer

Handy Splicer

TYPE-201e-VS/M4

Guide to operation



IMPORTANT SAFETY PRECAUTIONS

This product has been designed and manufactured to assure personal safety. Improper use can result in fire, electric shock or injury to persons. Please read and observe all warnings instructions given in this operation manual.

Use your splicer only for its intended purpose.



◆ **The meaning of these symbols**

In the product and this operation manual, symbols are used to highlight warnings and cautions for you to read so that accidents can be prevented. The meanings of these symbols are as follows:



○Symbol used in the product

	This symbol, where it appears on the unit, indicates that hazardous voltage is present inside of the splicer.
---	---

○The meaning of these symbols

	This symbol indicates a warning, caution, or danger and alerts you important instructions have been included on the product or in the manual.
	This symbol indicates actions that are prohibited.
	This symbol indicates actions that must be taken.

○The meaning of Warning and Caution

 Warning	This symbol indicates explanations about extremely dangerous matters. If users ignore this symbol and handle the splicer the wrong way, serious injury such as fire or electric shock, or death could result.
 Caution	This symbol indicates explanations about dangerous matters. If users ignore this symbol and handle the splicer the wrong way, bodily injury and damage to the equipment could result.

Be sure to read all the following warnings and cautions before use.

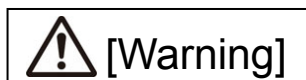

<Setting up, transportation and using splicer>



	<ol style="list-style-type: none"> 1. This fusion splicer performs an arc discharge. Do not use the splicer in a hazardous location in which inflammable gas can generate or only electrical apparatus for explosive gas atmosphere can be used. 2. Never use spray cleaners such as Freon or Flammable gas on the splicer. Decomposition of arc by heat will cause toxic gas, or abnormal arc may result in damage or fire.
---	--





3. Do not use and store the splicer out of the locations defined in a brochure and this manual. Doing so can cause splicer malfunction or deterioration, resulting in fire or electric shock.
4. To reduce the risk of fire, electric shock or malfunction, do not allow the splicer to be exposed to rain and get liquid such as water or a metallic object inside the splicer. Doing so can cause fire, electric shock or malfunction by shorting out internal components.
5. Never use the battery pack, AC adapter and battery charger, and power cables for the machines other than the specified splicer. Doing so can cause these items to damage, resulting in fire or heat generation.
6. Do not make mechanical or electrical modifications to the splicer since this may expose you to dangerous voltage or other hazards.
7. Do not touch the electrodes during and after arc discharge. Doing so can cause personal injury or electric shock.
8. The heating plate of the heat shrink oven may be hot during heating. Do not touch the protection sleeve directly after heating. Doing so can cause burn. A protection sleeve may also be hot after heating. Handle with care.
9. Do not operate the splicer in the rain. Doing so can cause AC adapter or battery pack to be short-circuited.
10. Do not expose the splicer to extremely high temperature and high humidity or to direct sunlight for prolonged periods.
11. Do not continuously use the heat shrink oven for long hours, keeping it high temperature. Doing so can cause heat shrink oven to malfunction.
The following case is the exception for repairing and replacing the product free of charge:
The Heating duration is set to a long time (e.g. 180 sec.) and the Finish temperature is set to a high temperature (e.g. 200 °C). The heat shrink oven is used for long hours by continuing to press the Heat key shortly after the heat cycle is completed.
12. Only use alcohol to clean the splicer. To prevent malfunction and damage, do not use any other kind of chemicals.
13. Never use spray cleaners such as Freon or flammable gas on the splicer. Heat by arc can cause chemical reactions to occur to gas component, which will deteriorate a microscope lens, resulting in a loss of splicing capability.
14. Parts that compose the heat shrink ovens might become high temperatures. When those parts are damaged, do not use it and contact our service center.
15. Because it is likely to injure by shards of glass when the monitor is damaged, do not use it and contact our service center.
16. When parts that compose this product and the accessory (battery pack, AC adapter, and power cord, etc.) are damaged, do not use it and contact our service center.
17. If this product gets wet with dew or the like, do not turn it on.
18. Do not use this product near the electronic equipment that handles a highly accurate control and the faint signal such as the heart pacer. The influence of the miss-operation of electronic equipment might be given.
19. Alcohol is prohibited on air transportation. Empty alcohol dispenser before transportation.

	<p>20. Avoid places with too much dust or dirt. Dirt or dust that can accumulate in the fusion splicer causes short circuit and insufficient cooling, which may lead to splicer malfunction or deterioration, resulting in fire or electric shock.</p> <p>21. Only use the battery pack, AC adapter, battery charger and power supply cord for the splicer as defined in this manual. Failure to do so can cause these items or the fusion splicer to damage, resulting in fire or electric shock.</p> <p>22. Only use a voltage within the indicated power voltage. Failure to do so can cause fire or electric shock.</p> <p>23. Check for condensation before operation. If this product gets wet with dew or the like, leave it in a room temperature for about one day before turning it on. If water or other liquid, a metallic object or other foreign substance gets inside the splicer, immediately turn off the power and disconnect the power plug. Contact our qualified service personnel.</p> <p>24. In a high location, take safety measures to prevent fall of operators. Dropping the splicer could result in personal injury. Fix the splicer to a worktable or a tripod on the bottom of the splicer.</p> <p>25. If an abnormal condition such as unusual noise, smoke or unusual odor occurs, immediately turn off the power and disconnect the power plug. Next, contact our qualified service personnel.</p> <p>26. Be sure to turn off the splicer and unplug the power cord or remove the battery pack before replacing the electrodes.</p> <p>27. Only use Sumitomo genuine electrodes (ER-11). And use the splicer with electrodes installed in it. Failure to do so can cause the splicer to damage, resulting in fire, electric shock or malfunction.</p> <p>28. When using the neck strap, secure the strap bracket to the splicer with a dedicated screw firmly. While using the neck strap, pay great attention not to hook any projections such as cable to the neck strap. If something was hooked, your neck would be wrung and choked. It is very dangerous.</p> <p>29. If the heat shrink oven keeps running for a prolonged time, the surrounding parts may become hot. Pay attention to the heat particularly in a high temperature environment and use protective gloves as needed.</p> <p>30. The supplied alcohol dispenser is not an airtight container. Pour alcohol into an airtight container before transportation, so it does not spill out.</p>
---	--

<Handling of power cord and plug >



	<p>1. To reduce the risk of electric shock, do not plug/unplug the power cord or remove the battery pack with wet hands.</p>
	<p>2. Disconnect the power cord by grasping the plug, not the cord. Failure to do so can cause damage to the power cord, resulting in fire, electric shock or malfunction.</p> <p>3. Before charging the battery pack, make sure that the pins of the battery charge cord are not bent or broken. Using the battery charge cord with a bent or broken pin can cause internal short circuit, resulting in fire or electric shock.</p>

<Handling of battery pack>



	<ol style="list-style-type: none">1. Do not burn the battery pack or throw it into a fire. Doing so can cause heat generation, bursting and fire.2. Do not place the battery pack in microwave ovens and high-pressure containers.3. Do not let water or sea water wet or soak the battery pack. Safety and protective devices to prevent danger are built in the battery pack. If these devices are damaged, excessive current flow can cause abnormal chemical reaction in battery fluid, heat generation, bursting and fire.4. Do not throw or impact the battery pack. Safety and protective devices to prevent danger are built in the battery pack. If these devices are damaged, excessive current flow can cause abnormal chemical reaction in battery fluid, heat generation, bursting and fire.5. Do not pierce the battery pack with nails, strike the battery pack with a hammer, or step on the battery pack. Doing so can cause internal short circuit, heat generation, bursting and fire.6. Do not disassemble or modify the battery pack. Safety and protective devices to prevent danger are built in the battery pack. If these devices are damaged, excessive current flow can cause loss of control during charging or discharging of the battery pack, heat generation, bursting and fire.7. Make sure the polarities are correctly connected. Do not attempt to connect the battery pack or other equipment when you cannot do. Reversed connections can cause abnormal chemical reaction in battery fluid, heat generation, bursting and fire.8. Do not solder any lead wires directly to the battery pack. Do not directly connect the positive and negative terminals with a conductive material such as a wire. Do not carry or store the battery pack together with any personal jewelry, hairpins or other Metallic objects. Doing so can cause an electrical short circuit. Also excessive current flow can cause abnormal chemical reaction in battery, heat generation, bursting and fire.
	<ol style="list-style-type: none">9. Only use a specified battery charger. Failure to do so can cause the battery to be overcharged or excessive current flow can cause abnormal chemical reaction in battery fluid, heat generation, bursting and fire.10. Use the battery pack only for the application for which it was designed. Failure to do so will result in a loss of performance and a shortened life expectancy. Also excessive current flow can cause loss of control during charging or discharging of the battery pack heat generation, bursting and fire.





<Transportation and storage>

	<ol style="list-style-type: none">1. This product is a precision instrument. When transporting the splicer, use its specified carrying case to protect the splicer from excessive shock or impact.2. Do not use and store the splicer out of the locations defined in a brochure and this manual. Failure to do so can cause splicer malfunction or deterioration, resulting in fire or electric shock.3. Do not store any items other than the product, package contents and optional accessories in the carrying case. Overloading the case can cause damage to the body of the carrying case, case handle, strap and latch.4. Do not throw or fall the carrying case. Doing so can cause damage to the body of the carrying case, case handle, strap and latch.5. Do not use a carrying case where there is a visible sign of damage and screw looseness.6. Do not store the hand strap in the windshield. It causes damage to the machine.7. Do not carry the machine grabbing the hood or the monitor.8. Do not brandish the machine with the hand strap, and brandish neither AC adapter nor the power cord. There are fear of machine damage and the injury.9. Do not use the machine with the lid of the battery Pack slot opened.
	<ol style="list-style-type: none">10. When shipping this product, inform the transport company that this product contains the lithium-Ion battery. Follow the direction of the transport company.11. Before carrying the case, make sure that there is no visible sign of damage and screw looseness on the handle and latch. If the case with damage and screw looseness is carried, it could drop down, causing personal injury or splicer malfunction.12. Before picking up the case, ensure that the latch is completely locked. Carrying the case with the latch unlocked can cause the case to fall open and result in personal injury or splicer malfunction due to heavy impact.13. Be careful that your fingers not to be caught in the hinge part and the lid when you open and shut the case.14. Confirm the work table of the carrying case is surely fixed to the case when you carry it.15. Do not modify the handle, strap or strap attachment points. Only use the carrying strap supplied by us.16. Avoid places with too much dust or dirt. Dirt or dust that can accumulate in the fusion splicer causes short circuit and insufficient cooling, which may lead to splicer malfunction or deterioration, resulting in fire or electric shock.17. If you are not going to use the splicer, remove the battery pack from the splicer. Failure to do so will shorten a battery life.18. Unplug the fusion splicer or remove the battery pack before attempting any maintenance or if not using the splicer for a prolonged period. Failure to do so can cause fire.19. The monitor, the hood, and the heater clamping, etc. do the opening and shutting operation. Be careful of your fingers not to be caught.

<Battery handling and charging>

	<ol style="list-style-type: none"> 1. Make sure the polarities are correctly connected. Do not attempt to connect the battery pack or other equipment when you cannot do. Reversed connections can cause abnormal chemical reaction in battery fluid, heat generation, bursting and fire. 2. Do not carry or store the battery pack together with any personal jewelry, hairpins or other Metallic objects. Doing so can cause an electrical short circuit. Also excessive current flow can cause abnormal chemical reaction in battery fluid, heat generation, bursting and fire. 3. Do not use a dry cell battery and the batteries differing in capacity, type, and manufacturer. Doing so can cause heat generation, bursting and fire.
	<ol style="list-style-type: none"> 4. The battery's optimum charging temperature range is 0 to 40°C. Under high temperature conditions such as in direct sunlight or near a fire, safety and protective devices to prevent danger which are built in the battery pack will be activated, resulting in failure of charging. Or if these devices are damaged, excessive current flow can cause loss of control during charging or discharging of the battery pack, heat generation, bursting and fire. Avoid charging the battery pack at extremely low temperature (below 0°C). Failure to do so may lead to deterioration in performance and battery leakage. 5. Always turn off the power to the splicer after use. Failure to do so can cause the battery to be over discharged and deteriorated in performance. 6. In the event the fluid inside the battery leaks, take extremely care not to expose it to your eyes and skin. If it does, immediately wash them thoroughly with clean water enough from the tap and consult a doctor urgently. 7. Unplug the fusion splicer or remove the battery pack before attempting any maintenance or if not using the splicer for a prolonged period. Failure to do so can cause fire. 8. Pay attention not to drop the battery pack when installing and removing it. Dropping the battery pack can cause personal injury.

<Handling of optical fiber >

	<ol style="list-style-type: none"> 1. Never look into optical fibers or the end of an optical cable attached to the optical output when the device is active. The laser radiation can seriously damage your eyesight.
	<ol style="list-style-type: none"> 2. Wear safety glasses at all times for protection from glass fibers.

< Others >

	<ol style="list-style-type: none"> 1. Do not press the keys on the keypad with a sharp object (e.g. a ballpoint pen, screwdriver, or nail) Doing so will damage the keypad. 2. Do not press strongly the touch screen with a sharp object. 3. Do not use or store the battery pack at high temperature, such as in strong direct sunlight, and in cars during hot weather. This can cause deterioration of the battery. 4. Even if you are not going to use the battery pack for a prolonged period, charge it once a year. 5. Do not press the liquid crystal display with force or the display may fail. 6. Take care to keep spliced fiber straight. Do not flex it back and forth. Doing so can cause the spliced fiber to be broken, resulting in loss of the long term reliability of the fiber. 7. Do not use a canned air for cleaning. Chemical reaction may deteriorate the lens, resulting in a loss of splicing capability.
---	--



8. Check the voltage of AC power before use. The AC adapter should be grounded to earth. If voltage or frequency beyond the range stated flows in the AC adapter, a safety and protective device to prevent danger is activated and the AC adapter will stop. In that case, a new AC adapter should be purchased. Please contact our qualified service personnel.
9. Charge the battery pack within the following temperature range. Failure to do so may lead to deterioration in performance.
*Battery pack's required temperature range: 0°C ~ +40°C
10. Before using the battery pack for the first time, charge it.
11. The battery pack is consumables. Repeated charging and discharging decreases battery life.
12. Store the battery pack within the following temperature range. Failure to do so may lead to deterioration in performance.
*Battery pack storage temperature range: -20°C ~ +50°C (if stored for less than 1 months) -20°C ~ +40°C (if stored for less than 3 months) -20°C ~ +20°C (if stored for less than 1 year)
13. Charge the battery pack fully before storing it for a prolonged period.
14. Even if you are not going to use the battery pack for a prolonged period, charge it once a year.
15. If you are getting fewer than splice cycles per fully charged battery, consider replacing the battery pack by a new one.
16. When disposing of the battery pack, contact our qualified service personnel or follow the local regulations.
17. Although bright spots or dark spots may appear on the screen, this is a unique characteristic of liquid crystal displays, and such do not constitute or imply a machine defect.
18. We recommend your splicer to be annually over-hauled to keep it in good condition.
19. Glass fiber fragments are extremely sharp. Handle with care.
20. Turn off the splicer before maintenance work. Failure to do so can cause electric shock.
21. Be sure to remove moisture, alcohol or dust on the heater element with a dry cotton swab.
22. Only use Sumitomo genuine electrodes (ER-11). Failure to do so can cause the splicer to malfunction.
23. Do not clean the electrode. Doing so can cause unstable arcing performance.
24. Storing and transporting the splicer with the battery pack installed can cause the battery pack to be damaged or deteriorated, resulting in fire. Remove the battery pack from the splicer before storage.
25. Transporting the splicer with fiber holders loaded can cause the V-grooves or clamps to be damaged, resulting in the failure of splice. Remove the fiber holders from the splicer before storage.
26. Ensure that the strap should be completely secured.
27. Whenever you use the strap rings, be sure to hold the splicer with your hand. Failure to do so can cause the splicer to turn over and accessories such as fiber holder will drop.

RoHS Directive (2011/65/EU)

The TYPE-201e-VS/M4 optical fusion splicer is RoHS-compliant.

WEEE Directive (Waste Electrical and Electronic Equipment; 2002/96/EC)

The European Union has enacted a Directive 2002/96/EC on Waste Electrical and Electronic Equipment (WEEE Directive). This directive is applicable in the European Union member states. The crossed out wheellie bin symbol found on our products indicates that it should not be disposed of together with household waste.

To prevent possible harm to human health and the environment, waste electrical equipment must be disposed of in an approved and environmentally safe recycling process.

For further information on how to dispose of the product correctly, please contact the product supplier, or the local authority responsible for waste disposal in your area.



IMPORTANT: REGION LIMITATION

WARNING:

This product is sold for the use in a limited sales area and the sale, resale, transfer, lease or otherwise of this product to the other regions is prohibited, except written consent of Sumitomo Electric Industries, LTD.

YOU NEED TO AGREE ABOUT A SOFTWARE LICENCE AND REGION LIMITATION BEFORE USE.

Reference of Sales Area and Sumitomo Sales & Service Representatives:

Sales Area	Sumitomo Sales and Service Representatives	
North & South America	SEL	Sumitomo Electric Lightwave Corp.
Europe, Middle east, Africa (EMEA) UK	SEEL	SEEL : Sumitomo Electric Europe Ltd.
China	SEA	Sumitomo Electric Asia, Ltd.
	SEAC	Sumiden Asia(Shenzhen) Co., Ltd.
Thai, Vietnam	SET	Sumitomo Electric(Thailand) Limited
Indonesia, Singapore	SEPS	Sumitomo Electric Interconnect Products (Singapore) Pte Ltd.
India, South Asia	SETI	SEI Trading India Pvt. Ltd.
Philippines	SEPI	SEI (philippines) Incorporated
Japan	SEI	Sumitomo Electric Indutries,Ltd.

Other sales area and authorized sales and service agencies may be provided according to the country, area and trading conditions. Refer to the information which appears on the splicer screen.

IMPORTANT: PATENT NOTICE

This product and/or the use of this product are/is covered by one or more of the following Patents of Sumitomo Electric Industries, LTD.:

Australia	Design No(s): 314929; 329420
Canada	Patent No(s): 2183840 Design No(s): 120205; 133128
China P. Rep.	Patent No(s): 98109577.1; 200780001246.9 Design No(s): 200730144402.X; 200930286514.8
Europe	Design No(s): 000712583-0001; 001183206-0001
Germany	Patent No(s): 0880039;
Sweden	Patent No(s): 0880039;
United Kingdom	Patent No(s): 0880039;
India	Design No(s): 209372; 225957
Japan	Patent No(s): 3065271; 3119822; 3952822; 4196972; 4305468; 4613796 Design No(s): 1311936; 1382022
Malaysia	Design No(s): MY07-00454-0101; MY09-01316-0101
Singapore	Design No(s): D2007/402/A; D2009/1085/Z
South Korea	Design No(s): 30-0472617; 30-0594853
Taiwan	Design No(s): D122221; D140150
United States	Patent No(s): 5,777,867; 6,206,583; 7,546,020 Design No(s): D578,072; D628,462S

IMPORTANT : TYPE-201e-VS/M4 SOFTWARE USER LICENSE

Copyright © 2014 SUMITOMO ELECTRIC INDUSTRIES, LTD. All rights reserved.

ATTENTION : The software installed in the TYPE-201e-VS/M4 SPLICER (“this software”) is the property of SUMITOMO ELECTRIC INDUSTRIES, LTD. The usage of this software is granted by a license. CAREFULLY READ AND THIS LICENSE BEFORE USING THIS PRODUCT.

The copyright and all other rights to this software, its documentation and the writings concerning this software (“the writings”), which contain CD-ROM, operation manual, guiding document, data tables, command lists, writing information (photos, images, drawing, text) on appended other printed materials, shall remain with SUMITOMO ELECTRIC INDUSTRIES, LTD. By commencing the use of this software, you acknowledge that you have read the following license and indicate that you agree to its terms. In case of disagreement, contact SUMITOMO ELECTRIC INDUSTRIES, LTD. or our product supplier.

LICENSE AGREEMENT

This license is the entire agreement between SUMITOMO ELECTRIC INDUSTRIES, LTD. and you.

1. LICENSE

The following restricted rights are granted. YOU MAY :

- a) use on a splicer in which this software is installed.
- b) create or distribute a construction manual based on the writings on condition that you clarify their source.
- c) create an execution report of construction based on displayed information, and the writings.
- d) create a document (manual or execution report) concerning the maintenance of the splicer in which this software is installed or control its splice-quality upon displayed information and the writings.
- e) make one copy of the writings for archival or backup purpose.

2. RESTRICTIONS

The following act is forbidden on this license, except our prior written consent. YOU MAY NOT :

- 1) sell, distribute, rent, lease, transfer, or disclose the whole or part of the writings to the public or unidentified parties and transfer, disclose or display the electrical format of the writings through online media.
- 2) make copy of the writings except as permitted in this license.
- 3) reverse engineer, decompile, disassemble this software and analyze, modify or merge the program.

3. CONTRACTING PARTIES

If you rent, lease, transfer, or resell the splicer, in which this software is installed, to a corporation or other entity, then this agreement is formed by and between SUMITOMO ELECTRIC INDUSTRIES, LTD. and such entity. You shall be liable for such entity to agree to the same all conditions of this license.

4. TERM AND TERMINATION

This agreement shall continue in effect until terminated. You may terminate the agreement at anytime by stopping the use of the splicer in which this software is installed. If you fail to comply with any of the provision of this license, your license will be automatically terminated. Upon termination, you shall transfer the writings to the owner of splicer (In the case that you transfer the splicer to other corporation or entity) or return them to us, otherwise erase or destroy them by appropriate means. You shall forever hold in confidence all trade secrets brought by this license. Further you agree not to disclose to any third party.

5. LIMITATION OF LIABILITY

SUMITOMO ELECTRIC INDUSTRIES, LTD. and our supplier shall not be liable for consequential, incidental or accidental damages in connection with this software or this agreement and whether this software shall meet your special requirements, special efforts or special method beyond the range described in the operation manual concerning this software.

6. GENERAL

If any provision of this agreement is declared by the court of competent jurisdiction to be invalid, illegal, or unenforceable, such provision shall be severed from the agreement and the other provisions shall remain in full force and effect.

The followings are a registered trademark or trademark of Corning Incorporated.
Corning®, LEAF®, MetroCor®, ClearCurve™

TrueWave® is a registered trademark of Furukawa Electric North America, Inc.

BendBright® and TeraLight™ are a registered trademark or trademark of Draka holding.

CasaLight™ is a trademark of Prysmian Cables and Systems.

The followings are a registered trademark or trademark of Sumitomo Electric Industries, Ltd.
MicroCore™, Sumitomo Z™, PureGuide®, PureMetor®, PureAccess®, UltraAccess®

microSD and microSDHC logos are trademarks of the SD-3C LLC.



FlashFX® Pro™ is a trademark of Datalight, Inc.

Table of contents

IMPORTANT SAFETY PRECAUTIONS
IMPORTANT: REGION LIMITATION
IMPORTANT: PATENT NOTICE
IMPORTANT: TYPE-201e-VS/M4 SOFTWARE USER LICENSE

1. General	1-1
Product overview	1-1
Optical fiber requirement	1-1
Features overview	1-2
Standard package	1-3
Optional accessories	1-5
Consumables	1-6
Structure	1-7
Fusion splicer	1-7
V-grooves, electrodes, other components	1-8
Heat shrink oven	1-9
Input/output panel	1-9
Caution label	1-10
2. Splice / Protection	2-1
Preparing power supply	2-2
AC operation	2-2
Battery operation	2-3
Battery level check	2-4
Charging the battery pack	2-5
Precautions for battery pack	2-6
Operating procedures	2-7
Turning on the TYPE-201e-VS/M4	2-7
Initial screen	2-8
Stripping the fiber coating / Cleaning the bare fiber	2-9
Stripping the ribbon fiber coating / Cleaning the bare fiber	2-10
Cleaving the fiber	2-12
Inserting fibers into the splicer	2-14
Arc test	2-15
Arc test procedure	2-15
Fiber preparation	2-17
Starting the automatic splice	2-18
Splice protection	2-22
Drop cable splicing	2-24
Removing cable sheath	2-24
Fiber preparation procedures	2-25
Inserting fibers into the splicer	2-26
Splice protection	2-27
3. Daily cleaning and checking up	3-1
Cleaning	3-1
Names of components	3-1

Cleaning V-grooves	3-2
Cleaning bare fiber pads	3-2
Cleaning LEDs	3-2
Cleaning microscope objective lens	3-3
Cleaning heat shrink oven	3-4
Cleaning fiber holders	3-4
Replacing electrodes	3-5
Electrode replacement procedures	3-6
Packing and storage instructions	3-8
4. Functions	4-1
Splice and heater programs setting	4-1
Function settings	4-8
Maintenance settings	4-10
Splice data storage function.....	4-11
USB connection function.....	4-12
Software download via internet	4-12
Login function.....	4-12
Help function.....	4-13
5. Troubleshooting	5-1
Arc problems	5-1
Fiber breaking	5-1
Splicer does not power up	5-1
Warranty and repair service	5-2
Error message list	5-3
TYPE-201e-VS/M4 specifications	5-4

Sumitomo Electric Industries, Ltd. reserves the right to change the specification or design without notice and may therefore not coincide with the contents of this manual. E&OE

1. General

Thank you very much for purchasing the TYPE-201e-VS/M4 Handheld Fusion Splicer.

The TYPE-201e-VS/M4 automatically pre-inspects and aligns a pair of optical fibers with equipped microscopes, and then fuses them together with heat from an electric arc to form a low-loss splice. A protection sleeve is applied over the bare glass and cured in the built-in heat shrink oven.

Before using the TYPE-201e-VS/M4, read all instructions completely.



Read this manual carefully in its entirety to fully understand machine capabilities.

Product overview

Optical fiber requirement

There are 2 versions of the TYPE-201e splicer and they have different specifications as shown below. (For more information, please refer to the next sections.)

	TYPE-201e-VS	TYPE-201e-M4
Material	Silica glass	
Profile types	SMF (ITU-T G.652), MMF (ITU-T G.651), DSF (ITU-T G.653), NZDSF (ITU-T G.655), BIF (ITU-T G.657)	
Cable types	Drop cable, Indoor cable	
Fiber count	1	1, 2, 4
Fiber diameter	125 μ m	
Coating diameter	250 μ m, 500 μ m, 900 μ m	Single fiber coating dia: 250 μ m, 500 μ m, 900 μ m Ribbon fiber thickness: 280-400 μ m
Cleave length	5mm~10mm	10mm

Features overview

The TYPE-201e key features are:

- **Touch screen monitor** (For more information, refer to page 2-8.)
3.5 inch LCD monitor with touch screen operation enables to confirm fiber images easily. The splicer can be operated by touching the icons on the screen. The working efficiency has improved dramatically.
- **Auto start** (For more information, refer to page 4-9.)
In addition to the function that automatically starts the splicing process when the hood is closed, the function that automatically starts the heating cycle when fiber is placed into the heat shrink oven is provided.
- **Auto mode (Automatic splice mode)**
 - (1) Automatic fiber count detection (For more information, refer to 4-3.)
The feature is active on Auto mode. In the splicing process, it automatically detects the fiber count loaded and selects a suitable splice program for the detected fiber count.
 - (2) Automatic arc compensation (For more information, refer to 2-15.)
Auto mode has the feature to automatically compensate arc power at every fusion splice. Normally performing an arc test is not necessary.
- **Small and lightweight shape** (For more information, refer to 5-4.)
The small size and 860g lightweight body make it easier to work in confined and aerial places.
- **Lynx-CustomFit™ Splice-On Single Fiber Connectors**
Lynx-CustomFit(TM) Splice-On Single Fiber Connectors are available.
(Accessory kit for E-2000 Connector of Diamond is not available.)

Standard package

Here is an example of TYPE-201e-VS/M4 standard package.

Package contents (example)

Description	Part number	VS	M4
Fusion splicer	TYPE-201e-VS	1 pc	-
	TYPE-201e-M4	-	1 pc
Fiber holders	FHS-025	1 pair	-
	FHM-4	-	1 pair
AC adapter	ADC-1340A	1 pc	
Power cord	PC-AC<X>*	1 pc	
Spare electrodes	ER-11	1 pair (2 pcs)	
Cooling tray	FCT-201	1 pc	
Neck strap Kit	NS-201	1 pc	
Operation manual (CD-ROM)	OME1324123	1 pc	
Carrying case (with strap)	CCS-25	1 pc	

*X=2(American type), 3(CEE type), 5(British type), 6(Oseania type), 7(South American type)

The above package is an example. The package contents vary depending on the customers' requests.



Packing example (CCS-25)



*Sold separately

Packing example (CCT-201)

Optional accessories

The following optional accessories are provided for the TYPE-201e. For further details, please contact our sales personnel.

Part name	Part No.	Description
<Optional accessories for main unit>		
Battery pack	BU-12S	Li-ion battery for TYPE-201e
	BU-12L	Large capacity Li-ion battery for TYPE-201e
AC adapter	ADC-1340A	AC adapter for TYPE-201e
Battery charger	BC-12	Battery charger for BU-12S/12L
Fiber holders	FHS-025	For 0.25mm coated fiber
	FHS-05	For 0.5mm coated fiber
	FHS-09	For 0.9mm coated fiber
	FHM-2	For 2 fiber ribbon (For M4 type only)
	FHM-4	For 4 fiber ribbon (For M4 type only)
	FHD-1	For drop cable
	Lynx2-UML-S	For ϕ 3mm cord and ϕ 0.9mm single fiber
Working table	WT-201	Working table for TYPE-201e
Cooling tray	FCT-201	Tray for cooling down protection sleeves
Neck strap	NS-201	Neck strap for TYPE-201e
Dispenser	HR-3	Dispenser for alcohol
Transfer tool	TRT-201	To prevent twisting while transferring drop or thin cables
Carrying case	CCS-25	Soft case (small)
	CCT-201	Hard case (small)
	CC-201	Hard case
<Tools>		
Fiber cleaver	FC-7/7R	Fiber cleaver for single fiber and 8 fiber ribbon
	FC-6M/6RM	Fiber cleaver for single fiber and 12 fiber ribbon
	FC-6S/6RS	Fiber cleaver for single fiber
Jacket remover	JR-M03	Jacket remover for single fiber
	JR-6	Hot jacket remover for ribbon fiber
	BU-6	Li-ion battery for JR-6

Consumables

Fiber protection sleeves, electrodes and battery pack are consumables. Please place an order if you need any.

Part name	Part No.	Description	Quantity
Fiber protection sleeves	FPS-1	For single fiber ϕ 0.25mm~0.9mm Length 60mm, Cleave length \leq 16mm	50 pcs/pack
	FPS-40	For single fiber ϕ 0.25mm~0.9mm Length 40mm, Cleave length \leq 10mm	50 pcs/pack
	FPS-61-2.6	For single fiber ϕ 0.25mm~0.9mm Length 60mm, Cleave length \leq 16mm	100 pcs/pack
	FPS-5	For single fiber and up to 8 fiber ribbon Length 40mm, Cleave length \leq 10mm	25 pcs/pack
Fiber protection sleeve for cable sheath	FPS-D60	For drop cable, small-sized indoor cable Length 60mm, Cleave length \leq 10mm	25 pcs/pack
Electrodes	ER-11	These parts degrade with time and usage and cannot be recycled. New parts as a replacement should be purchased.	1 pair
Battery pack	BU-12S/12L		1 pc

- Regarding standard equipment, consumables, or optional accessories, please order the new item you need with the item description and part number to our sales personnel.
- For repair, please read “Warranty and repair service” at page 5-2 and contact our maintenance service center.

Structure

Fusion splicer



1 Main body

TYPE-201e fusion splicer

2 Switch

Power ON/OFF switch

3 Touch screen monitor

Displays fiber image, splice data and menu. Touch screen operation enables to start splicing, heating and feature setting.

4 Hood

Provides protection from the environment.

5 Heat shrink oven

Heat shrinks fiber protection sleeve.

6 DC-IN cover

Cover for DC input.

7 Input/output panel

Cover for microSD card slot and USB port.

V-grooves, electrodes, other components

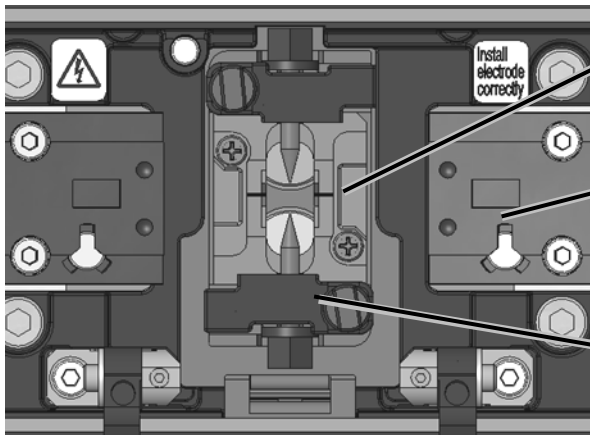

1 V-grooves

Keep bare fibers aligned.

(The example picture on the left shows the VS type.)

2 Fiber holder stage

A fiber holder is placed on the stage.

3 Electrode cover plate

Holds the electrode seated into the retaining groove.

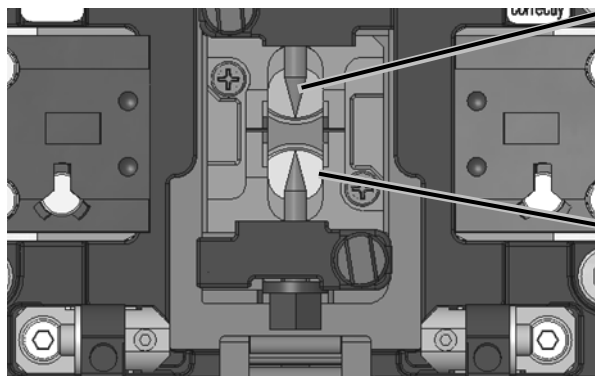

4 Electrodes

Arc is generated between the electrodes.

5 Microscope objective lens

Fiber is observed with the lens.

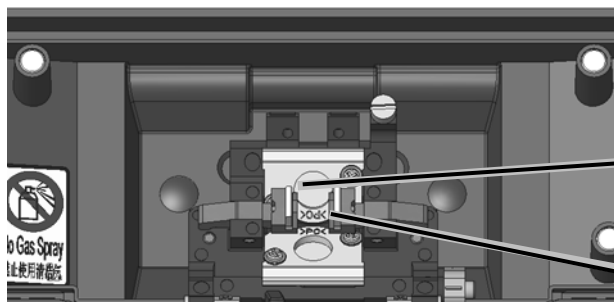

6 LED for fiber observation

7 Bare fiber pads

Hold fibers seated into the V-grooves. Normally they are attached to the hood.

(The example picture on the left shows the VS type.)

Heat shrink oven

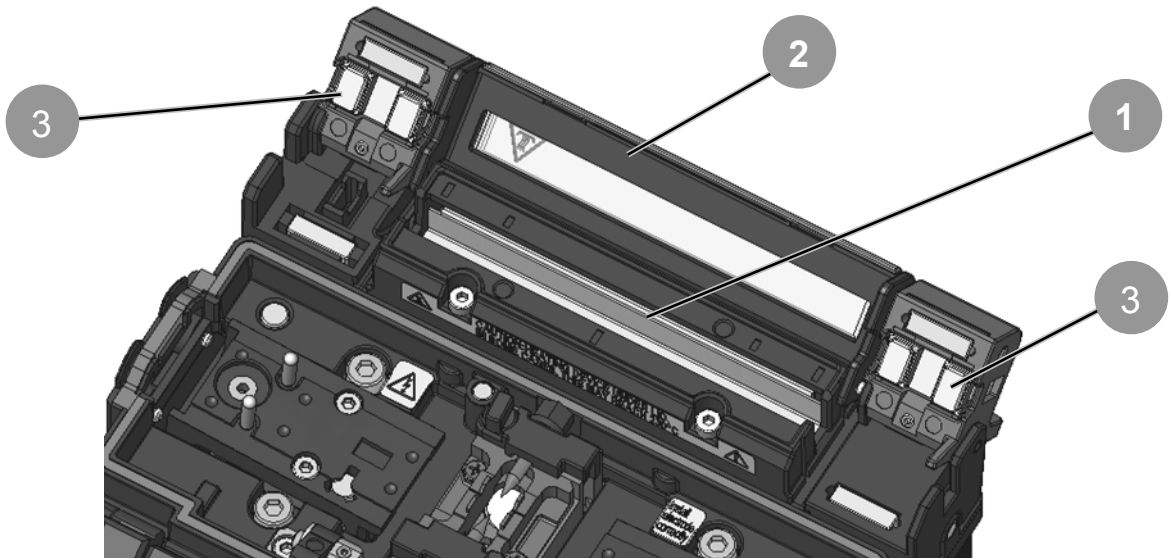

1 Heating plate
Heats fiber protection sleeve.

2 Heat shrink oven lid
Closed during the heating process.
Prevents the heating plate from
being touched.

3 Clamp
Hold fiber coating straight.

Input/output panel

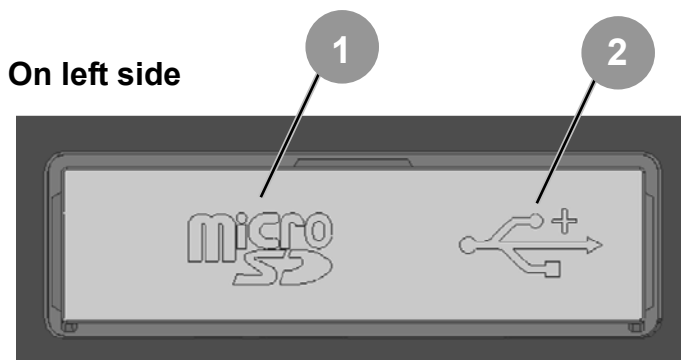

1 microSD card slot
A slot for a microSD card.

2 USB port
Used to download stored splice loss
data when connected to a PC.

On right side

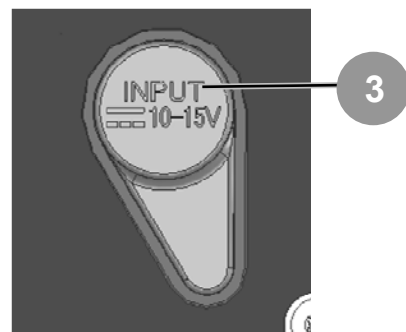

3 DC input terminal
Input power via AC adapter.

Caution label

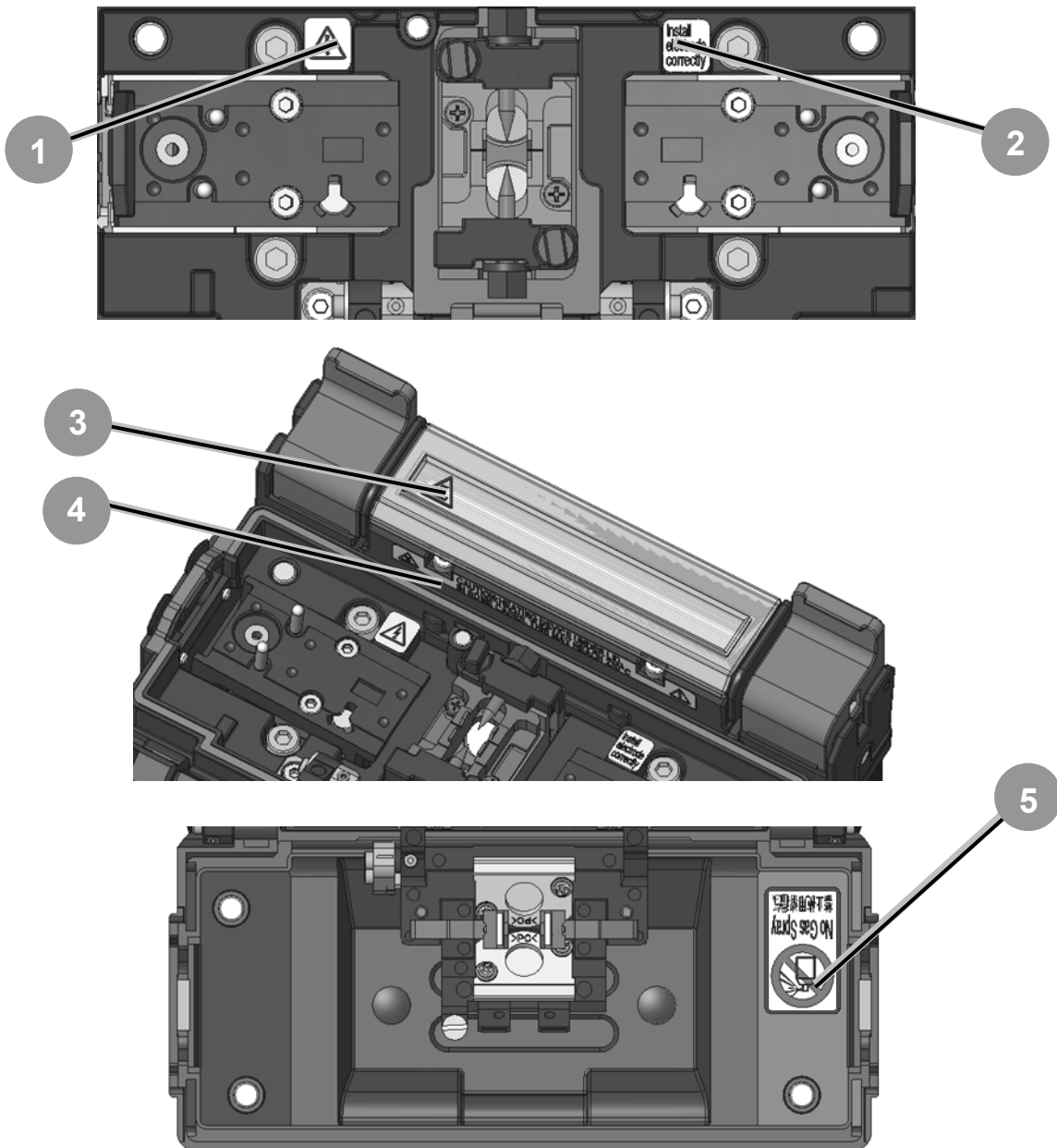

1 High voltage

When the arc is discharged, a high voltage is generated in the electrode. Please pull out the power cord, and detach the battery pack when you touch the electrode.

2 Installing electrode

Please confirm whether the electrode is installed without fail before splicing.

3 High temperature heater

Heater may reach 200°C.

4

Please take care when you use heater.

5

Prohibition of using spray

Do not use any gas spray such as gas duster or canned air.

2. Splice / Protection

[Preparation for splicing]

Before splicing, collect all of the necessary equipment.

- TYPE-201e-VS/M4
- Optical fiber being spliced
- Jacket remover
- Fiber cleaver

- Pure (more than 99%) alcohol
- Lint-free gauze wipes
- Fiber protection sleeves*

*The protection sleeves being used are different depending on the fiber being spliced.

[Operating procedures]

The following is a summary of the steps required to make a splice with the fusion splicer. For further information on each step, please see the page described below.

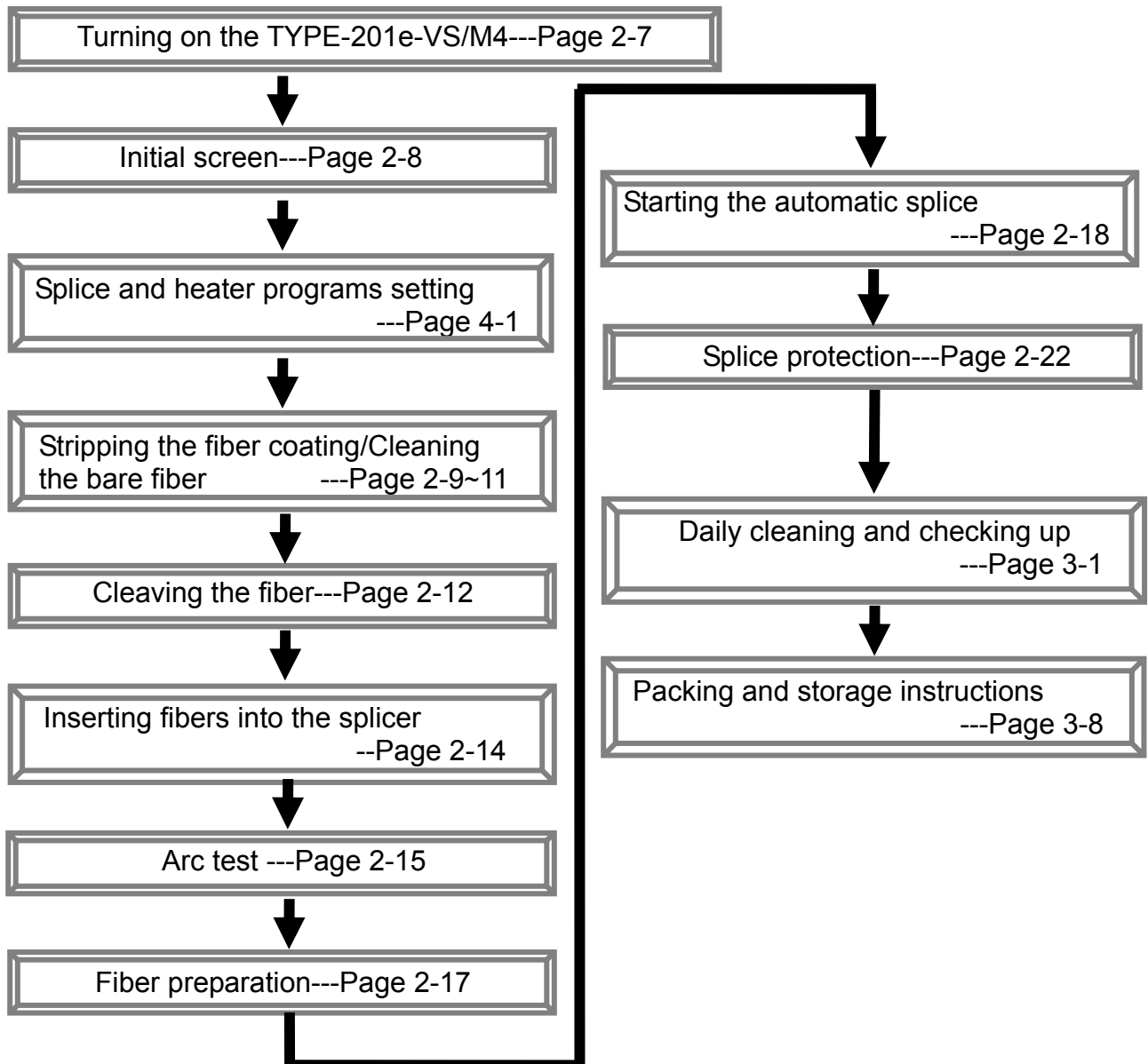

Preparing power supply

The power for TYPE-201e-VS/M4 is supplied by AC adapter or battery.

AC operation

Please connect AC adapter (ADC-1340A) with TYPE-201e-VS/M4 when you operate with the AC adapter.

Plugging

Insert the power cord into the AC adapter completely.

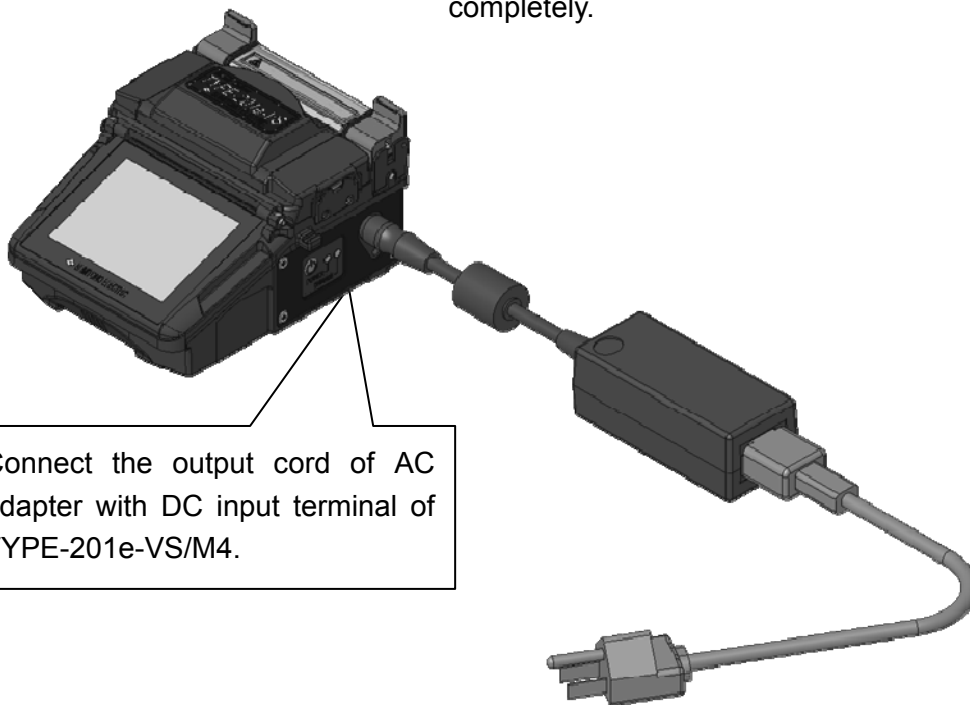

Connect the output cord of AC adapter with DC input terminal of TYPE-201e-VS/M4.

1. Please confirm the voltage of the AC power supply before using. Moreover, please earth the AC adapter by using the power cord with the earthing terminal.
2. The security function might work for safety when the voltage and the frequency outside the specification range are input to the AC adapter and the AC adapter stop operating. In this case, it is necessary to exchange AC adapter for a fee. Please contact our maintenance service center.
3. Please arrange the AC adapter to pull out the power cord immediately in the emergency. (Do not arrange the AC adapter out of reach.)
4. Please use battery power at an altitude of 2000m or higher.



Battery operation

Please install a battery pack (BU-12) in the battery pack slot of TYPE-201e-VS/M4. Turn off the splicer and disconnect the AC adapter before installing and removing the battery pack.

*Please check the charge before the battery pack is installed.
(Please refer to the page 2-4 “battery level check”.)

Installing battery pack

1. Fit the battery pack to the battery pack slot with the battery label facing the battery pack compartment.



2. Slide the battery pack to the end until you hear a click sound.

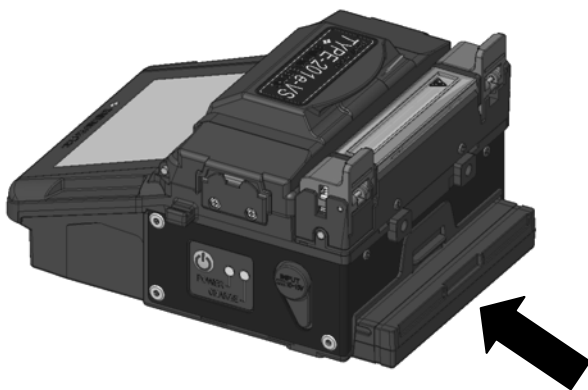

Removing battery pack

1. Keep pressing up the release latch.
2. Hook your finger to the concave part of the battery pack and slide it out.

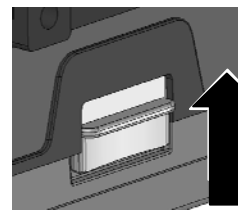
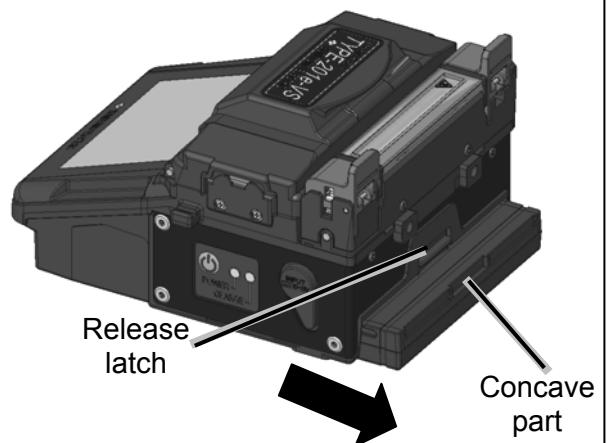





Enlarged view of
release latch



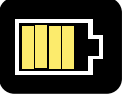
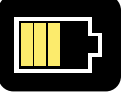

Battery level check

The battery icon in the monitor screen shows the battery level or charging status.

Battery level

Indicator	Meaning
	Battery remains enough. Over 80%
	61 to 80%
	41 to 60%
	21 to 40%
	Battery remains little. 1 to 20%
	No battery. Please charge the battery pack immediately.

Charging status

Indicator	Meaning
	Charging.
	Charging process is complete.

*Be sure to charge the battery pack before use when the battery level is low.

*There is no battery indicator when AC adapter is in use.

Charging the battery pack

1. Install the battery pack in the splicer.
2. Connect the AC adapter to the splicer and plug it in.
3. After a few seconds, the CHARGE LED (adjacent to the POWER LED on the side of the splicer) blinks in orange and the charging process starts.
4. The charging time varies depending on the remaining battery level and ambient temperature but approx. 3 hours at a maximum. When the charging process is complete, the CHARGE LED lights up.



The CHARGE LED shows the charging status.

Lighting (orange)	The charging process is complete.
Blinking (orange)	The battery pack is charging.
Off	<ul style="list-style-type: none"> • Battery pack is not installed in the splicer. • AC adapter is not connected to the splicer. • The battery pack is charged outside the charging temperature range (0~40°C). If none of the above applies, the battery pack could be malfunctioning. Contact our maintenance service center or follow the local regulations.

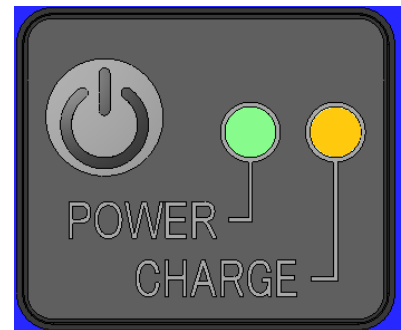

The battery pack can be charged while the splicer is in use. However the charging time is longer than charging when the splicer is off. (It takes approx. 20 hours (only as a guide) to complete the charge.)



Please charge the battery pack in the following temperature range. The battery pack might be deteriorated (decrease in capacity) at the temperature that exceeds this range.

***Temperature range for charging: 0°C~+40°C**

Charging in low temperature may reduce a charged capacity compared with charging in room temperature

Precautions for battery pack

- **Before using the battery pack for the first time, charge the battery pack. (The battery is not fully charged before shipping.)**
- The battery pack is a consumable. Repeated charging and discharging decreases battery life.
- Store the battery pack within the following temperature range. Failure to do so may lead to deterioration in performance.
 - *Battery pack storage temperature range:
 - 20°C ~ +50°C (if stored for less than 1 month)
 - 20°C ~ +40°C (if stored for less than 3 months)
 - 20°C ~ +20°C (if stored for less than 1 year)
- Do not use or store the battery pack at high temperature, such as in strong direct sunlight, in cars during hot weather. This may cause leakage of battery fluid.
- If you are not going to use the battery pack for a long period, charge the battery pack once every 6 months.
- If you are not going to use the splicer, remove the battery pack from the splicer.

When should the battery be replaced?

When the splice frequency decreased extremely with fully charged battery, please purchase a new battery pack.

When disposing of the battery pack, contact our maintenance service center or follow the local regulations.

Operating procedures

Turning on the TYPE-201e-VS/M4

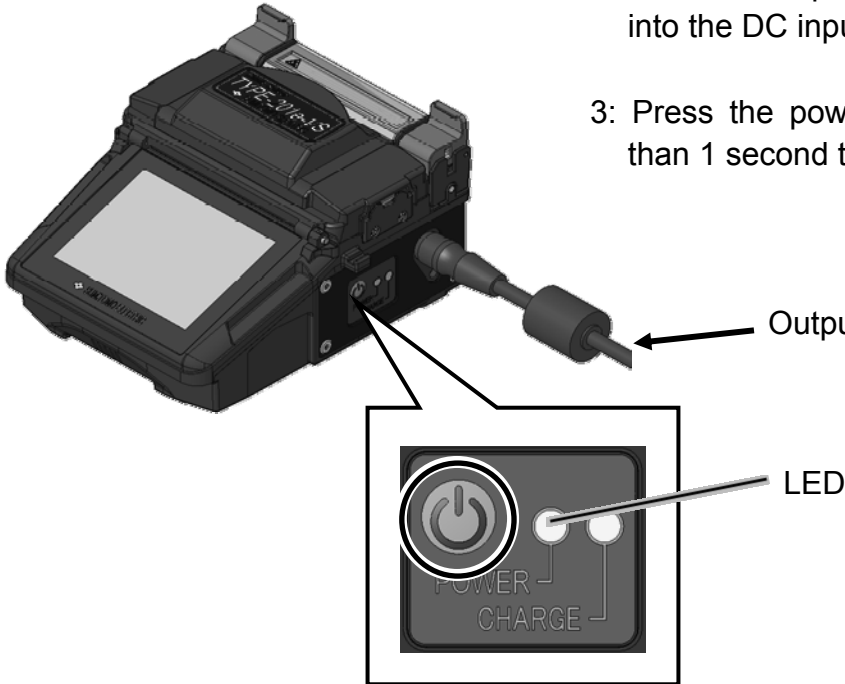

1: Ensure that the electrodes are fully inserted in the splicer.

2: Insert the output cord of the AC adapter into the DC input terminal.

3: Press the power () key for more than 1 second to turn on the power.

Output cord of the AC adapter

LED

POWER

CHARGE

If you press the power key right after connecting the power cord to the power supply module, it may take a few seconds until the splicer is powered on.

Special note on monitors

Although bright spots or dark spots may appear on the screen, this is a unique characteristic of liquid crystal displays, and such do not constitute or imply a machine defect.

Initial screen



Startup screen

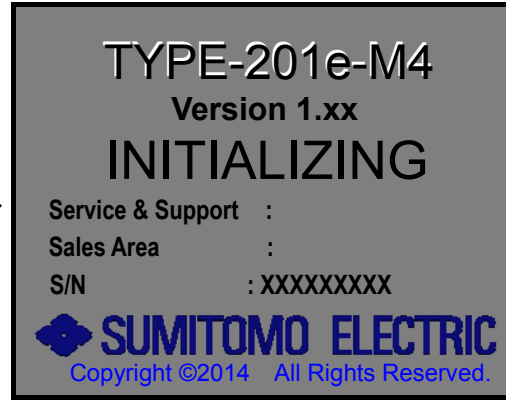
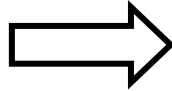

Initialize screen

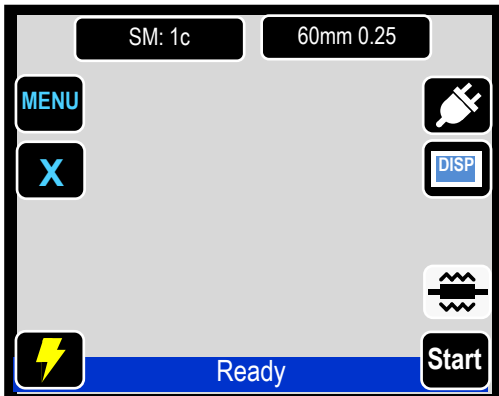

Initialization is complete.
→ Ready screen

Each motor of the splicer is initialized after turning on the power supply, and the ready screen is displayed after a few seconds. TYPE-201e-VS/M4 has the touch screen function that enables to operate by the icons on the screen.

The function of each icon in the ready screen is as follows.

MENU : Displays the main menu screen where various functions are selected.

SM: 1c : Shows splice program that is selected. You can go to splice program selection screen by touching it. Please refer to page 4-1 for how to select splice program.

60mm 0.25 : Shows heater program that is selected. You can go to heater program selection screen by touching it. Please refer to page 4-2 for how to select heater program.

X : Shows observation screen that is displayed on the monitor. The screen changes by every touch in this order X ⇒ Y ⇒ X/Y.

Start : Start to make a splice



: Shows power supply type (AC power supply). When the battery pack is in use, the battery indicator is displayed. (→ page 2-4)

DISP : Display/hide icons

: Start and cancel heating cycle



: Arc test

Stripping the single fiber coating / Cleaning the bare fiber

- 1: Clean the fiber coating thoroughly to remove cable gel or other stains.
- 2: Strip the fiber coating. (An example shows use of Sumitomo JR-M03 tool, strip length shown apply to any stripping tool. If you use another jacket remover, please refer to its operation manual.)

Use the correct groove of the remover suitable for the fiber coating diameter.

→ See figure <1>.

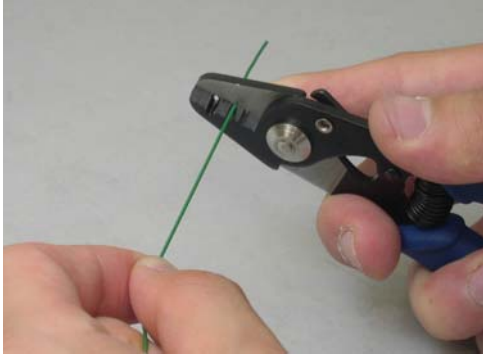

- 3: Strip Approx. 30~40mm of the fiber coating with the JR-M03 (ex). (If you use another remover, please refer to its operation manual.)

*If the stripping length is too long, the fiber cleaver may not store the off-cut in the off-cut collector.

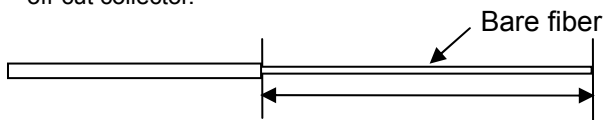

Stripping length= Approx. 30~40mm

<1> Check the fiber coating diameter.

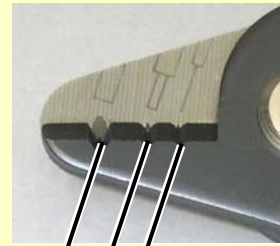

(1) (2) (3)

- (1) Fiber coating diameter : 1.6-3mm
- (2) Fiber coating diameter : 600-900 μ m
- (3) Fiber coating diameter : 250 μ m

The JR-M03 strips approx. 25mm of fiber coating at a time. To strip 30~40mm of the fiber coating, repeat the operation.

- 4: Repeat the stripping process for the other fiber.
- 5: Clean the bare fiber from the end of the fiber coating with a lint-free gauze pad moistened with pure alcohol. Pull the bare fiber through the gauze pad. Rotate the fiber by 90 degrees to remove any coating residue. Do not reuse the gauze pad that was used.

Keep the fiber squeaky clean.

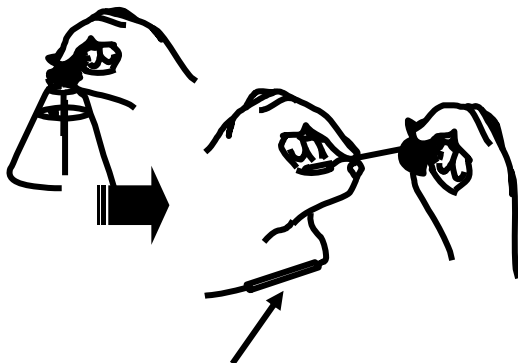

Fiber protection sleeve

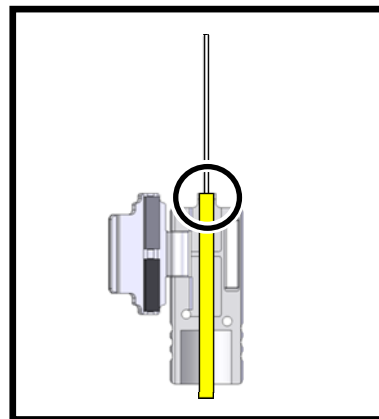

- 6: Place the fiber into the fiber holder. Ensure that the end of the fiber coating is aligned with the edge of the convex portion of the fiber holder.

Stripping the ribbon fiber coating / Cleaning the bare fiber

An example shows use of Sumitomo JR-6 hot jacket remover. Please read the JR-6 operation manual before use. If you use another jacket remover, please refer to its operation manual.

1: Turn on the power of the JR-6.



Press the POWER key for more than 1 second until the TEMP./BATT. indicator LEDs illuminate.

The indicator LEDs illuminate to indicate a current battery remaining capacity. Then the HEATER LED flashes in the red. The HEATER LED turns green when the JR-6 reaches the set temperature.

2: Place an optical fiber in a fiber holder with the ends protruding approx. 30mm.

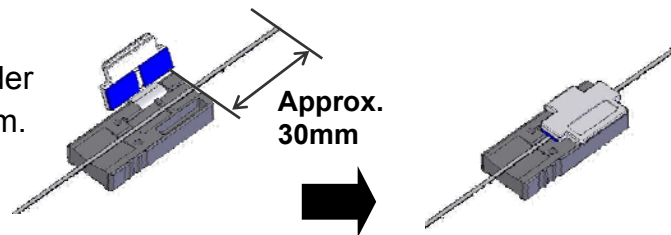

3: Place the fiber holder in the holder receptacle.

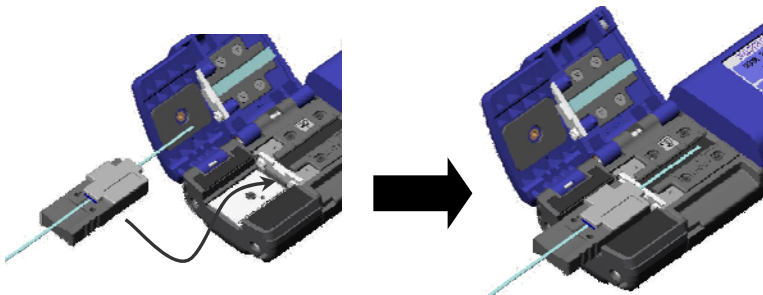

*Touch the edge of the fiber holder against the JR-6.

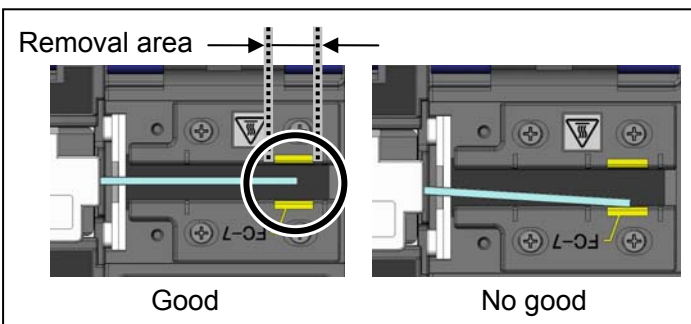

With use of Sumitomo fiber cleavers, ensure that the coating end is positioned in a specified area indicating "FC-7".

4: Close the main body lid and holder lid.

The HEATER LED flashes in green for approx. 5 seconds, and then keeps illuminated.

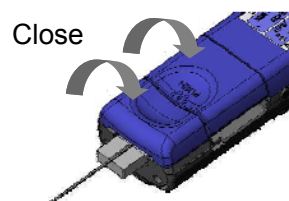

5: Ensure that the HEATER LED is lit in green and hold the JR-6, especially the “PUSH” portion of the main body lid firmly. Then slide the holder receptacle and holder lid slowly in the direction indicated by the arrow.

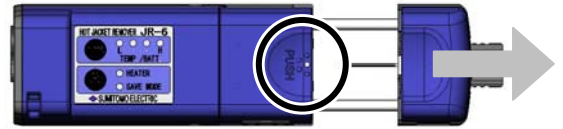

6: The fiber coating is removed. Take out the fiber holder from the JR-6.

7: Clean the bare fiber from the end of the fiber coating with a lint-free gauze pad moistened with pure (more than 99%) alcohol. Pull the bare fiber in the direction indicated by the arrow through the gauze pad. Do not reuse the gauze pad that was used.

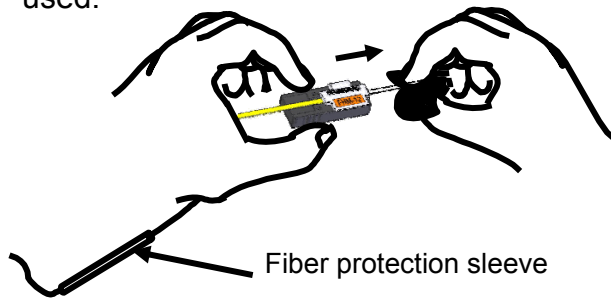

Keep the fiber squeaky clean.

8: Lightly brush the ends with your finger to fan out all fibers in a straight line.



9: Repeat the same procedures for the other fiber.

Cleaving the fiber

An example shows use of Sumitomo FC-6M fiber cleaver. Please read the FC-6M operation manual before use. If you use another fiber cleaver, please refer to its operation manual.

Standard cleave length: 10mm

1:

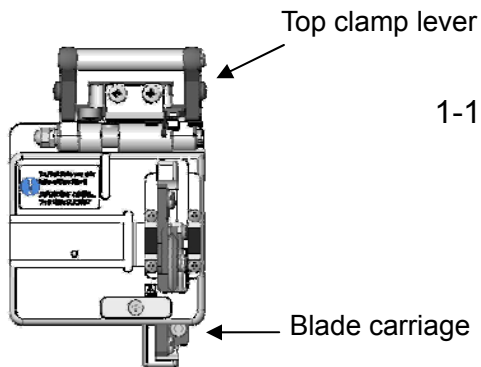

1-1: Open the coating clamp lid and the top clamp lever. The blade carriage should be in the forward position.

2:

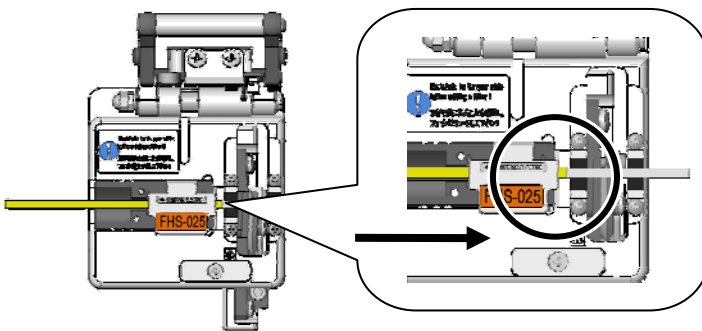

2-1: Place the fiber holder in the FC-6M. (Touch the edge of the fiber holder against the FC-6M.)

* Keep the fiber in the fiber holder after stripping the fiber coating/cleaning the bare fiber.

3:

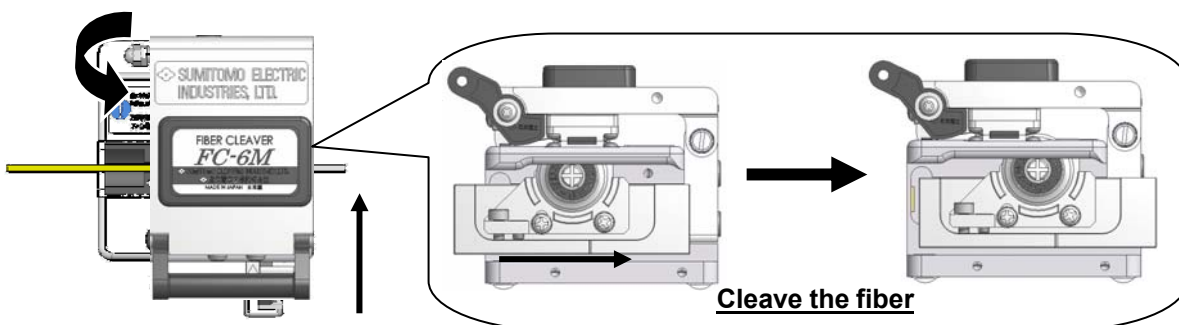

3-1: Lower the top clamp lever. Slide the blade carriage to the rear of the cleaver as indicated by the arrow.

4:

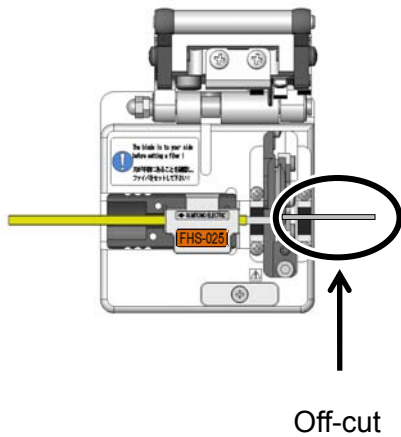

The fiber is cleaved.

4-1: Open the top clamp lever.

4-2: Lift the fiber holder.

4-3: Lift the off-cut and dispose of it properly.

*Be careful not to touch the off-cut against the fiber end face.

4-4: Place the fiber holder into the TYPE-201e-VS/M4.

4-5: Cleave the other fiber in the same way.



Caution

1. Do not re-clean the fiber after cleaving.
2. To avoid damaging or contaminating the delicate fiber ends, insert each fiber immediately after preparation.
3. Glass-fiber fragments are extremely sharp. Handle with care.

Inserting fibers into the splicer

1: Open the hood.

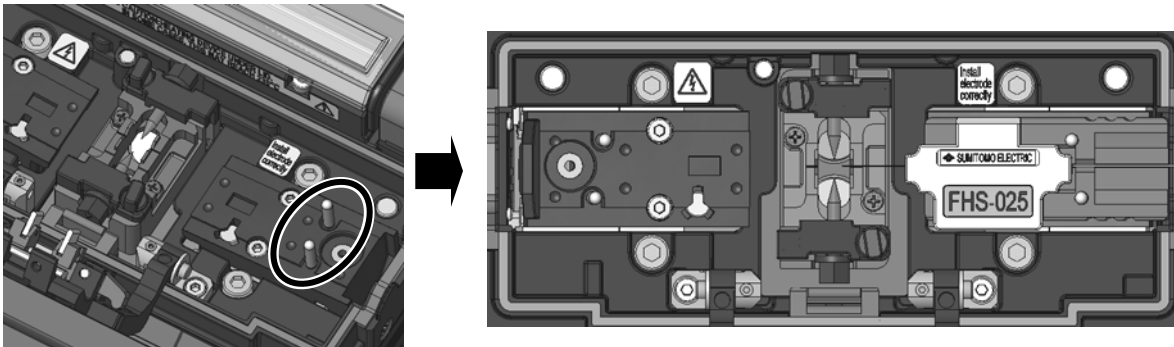

2: Place the fiber holder onto the holder stage, fitting the pin of the fiber holder stage into the hole of the fiber holder.

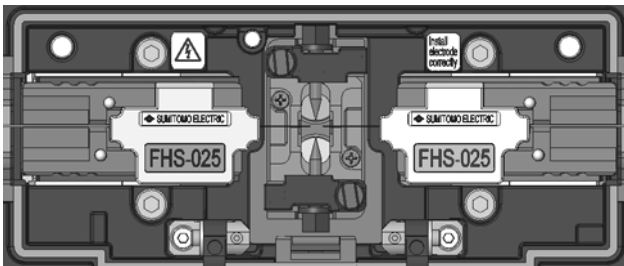

3: Place the other fiber holder in the same way.

Do not touch the fiber end face against any surface.

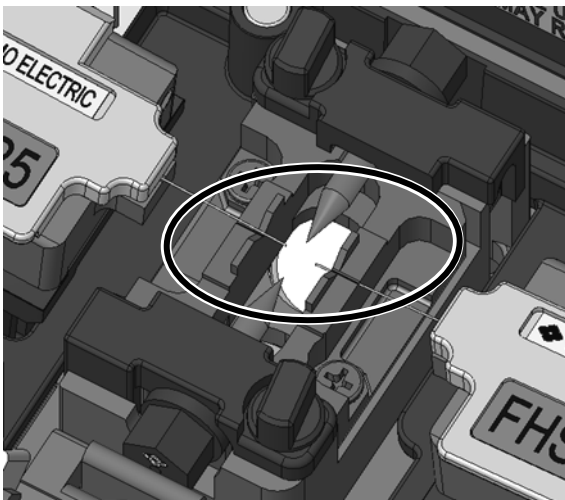

4: Ensure that the fibers are resting in the V-groove.

The position of fiber placement is different depending on the number of fibers.

Place the fiber in the correct V-groove according to the fiber being used.

5: Close the hood.

6: Start an arc test or the splicing process.

Arc test

The fusion splicing is a method of melting and connecting the point of the optical fiber by heat of electrical discharge. Because optimum arc conditions are different depending on environment (atmospheric pressure and temperature) and the electrode condition (wear-out and adhesion of the glass) and the optical fiber (manufacturer and SMF/MMF, etc.), appropriate arc condition is necessary to make a low splice loss. If you make a splice on standard program such as "SM:1c", perform an arc test with the fiber being spliced before fusion splicing.

In the Auto mode, TYPE-201e-VS/M4 analyzes the arc and has the function to calibrate the arc condition automatically at each splice. Therefore, arc test is not needed usually in the Auto mode.

As an exception, perform an arc test in the following situations to calibrate the arc power and position.

- Poor splice performance
(high or inconsistent splice losses, poor splice strength)
- After electrode replacement
- Extreme changes in temperatures, humidity or air pressure

Arc test procedure

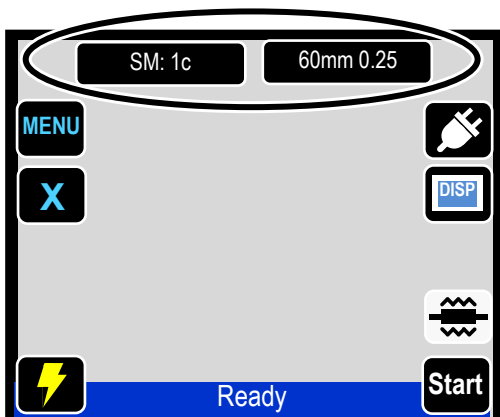

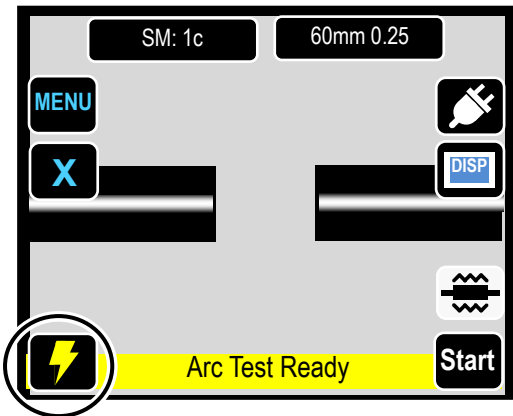

- 1: Place fiber that has been prepared. (The coating is removed and fiber is cleaved.)
- 2: Make sure whether the selected splice program and heater program is correct on the ready screen.

Regarding how to set and change program, please refer to the page 4-1 and 4-2 "Splice and heater programs setting".

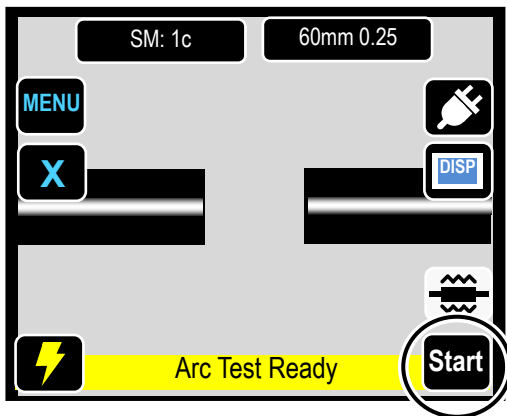

- 3: Touch the "Arc test" ().
- 4: "Arc Test Ready" screen will be displayed.



- 5: Touch the "Start" ().
- 6: An arc test is started. Fibers are not spliced because they are not moved forward during arc.

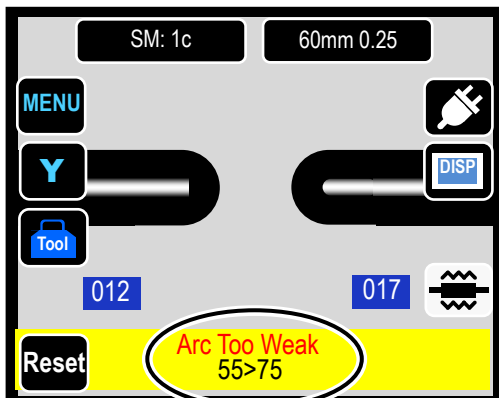

- 7: If "Arc Too Weak", "Arc Too Strong" or "Arc Center" is displayed, prepare the fiber again and repeat the test until "Arc OK" is displayed. The meltback distance of the left and right fibers and the arc center position which are measured via image processing are displayed on the monitor screen. (The arc center position is displayed only if the position is shifted.)

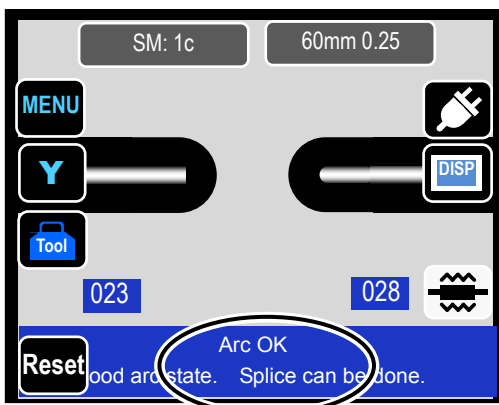

- 8: If "Arc OK" is displayed, begin the fiber preparation procedure to perform a splice. The splicer automatically initializes when the hood is opened.

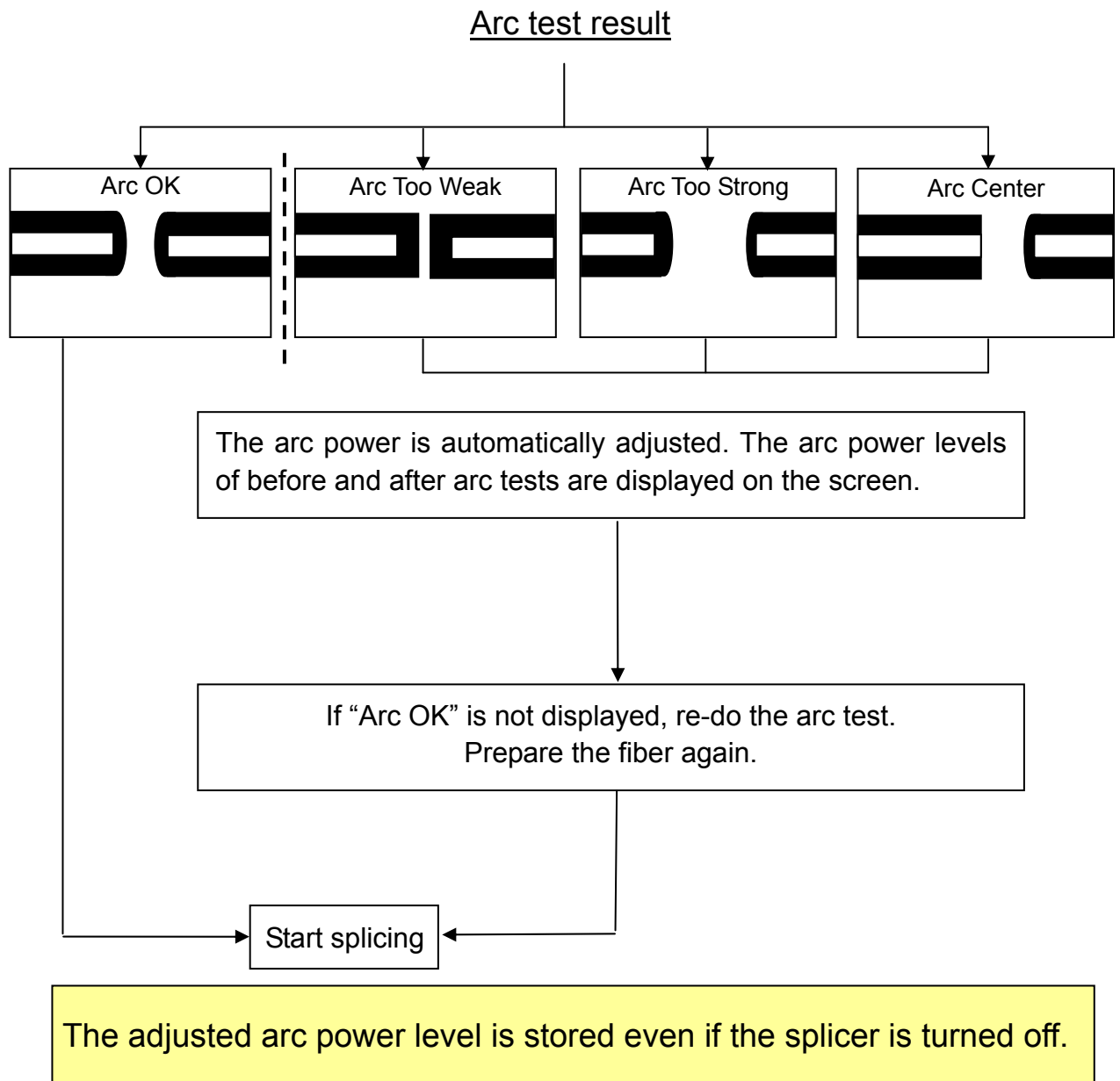

Fiber preparation

- 1: Be sure to slip the fiber protection sleeve over one of the fibers to be spliced before stripping and cleaving the fibers. The fiber protection sleeve cannot be installed after splicing.
- 2: Strip the fiber coating and clean the bare fiber.
Refer to page 2-9.
- 3: Cleave the bare fiber to proper cleave length.
Refer to page 2-12.
- 4: After setting the prepared fibers on TYPE-201e-VS/M4, splicing starts by touching "Start" (**Start**). (Please refer to the next page.)

Starting the automatic splice

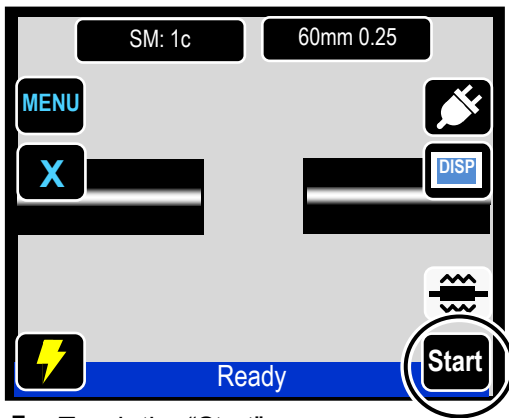

Touch the "Start".

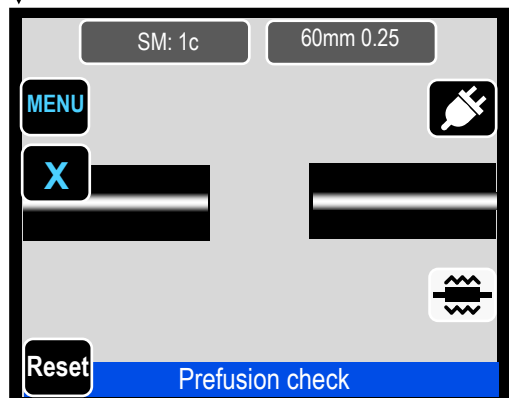

Inspection of fiber end face & dust

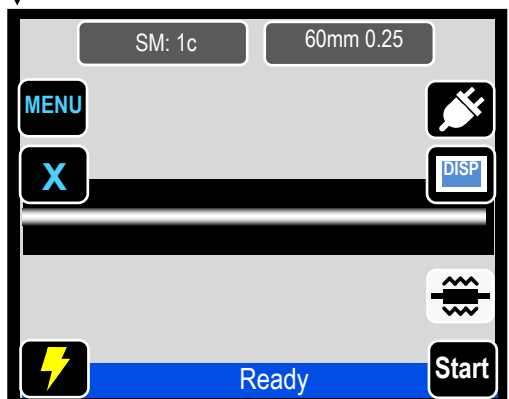

Arc is generated.

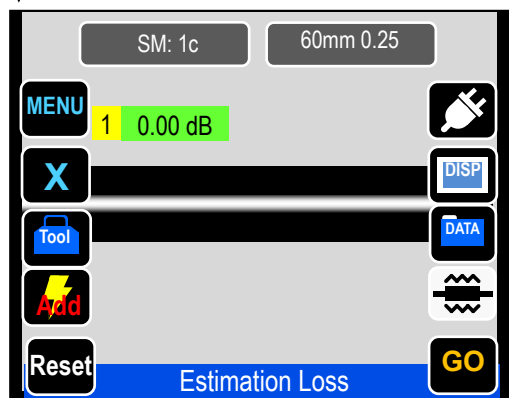

Estimated loss is displayed.

See the next page if you skip the checking of splice data and go on to the next step.

Checking splice data

- After a splice, touch the "Data" ([DATA]).

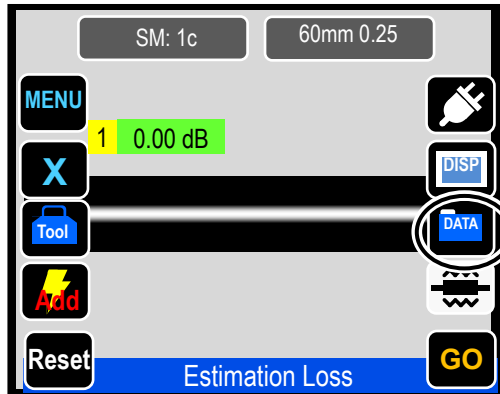

Confirm splice data.

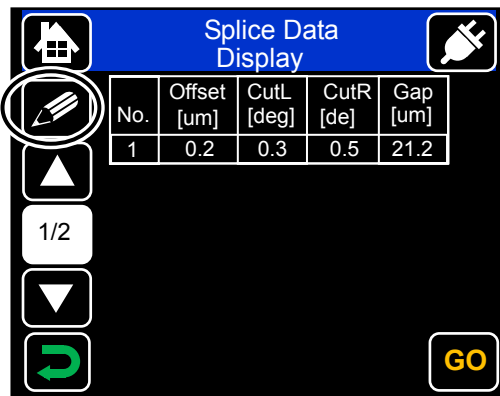

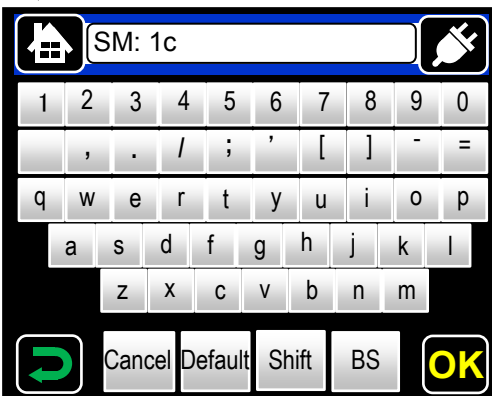

- Add the memo by touching "MEMO" ([MEMO]).

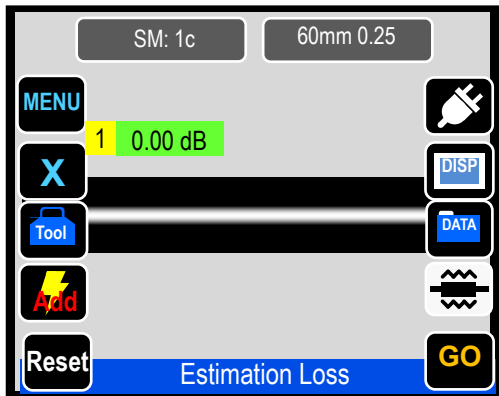

See the next page if you skip the checking of splice image and go on to the next step.

Checking splice image



Touch the “Tool” () after splice process completed.

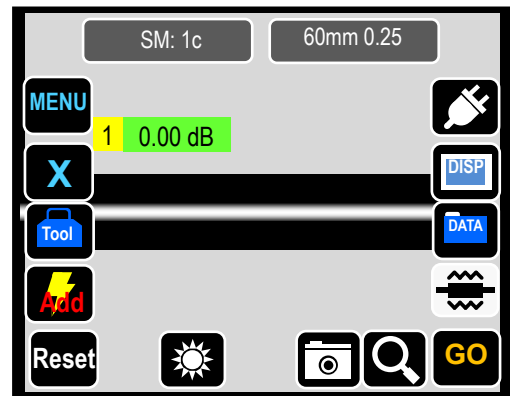

Icons of checking tools are displayed.

Checking Tools



: By touching an arbitrary place of the image, it is zoomed in and enlarged.



: Save the image to microSD card.



: Change the brightness of the image.

Proof test

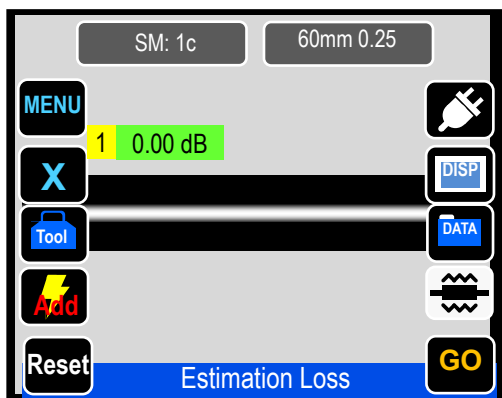

Open the hood.

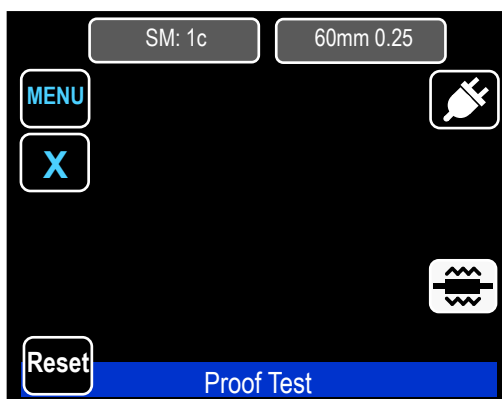

The proof test is automatically started.
(The test cannot be canceled once started.)



Remove the spliced fiber when the screen above is displayed.

(if manual proof test is selected)

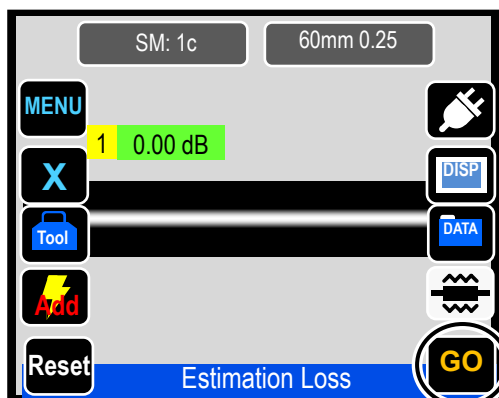

Touch "GO".

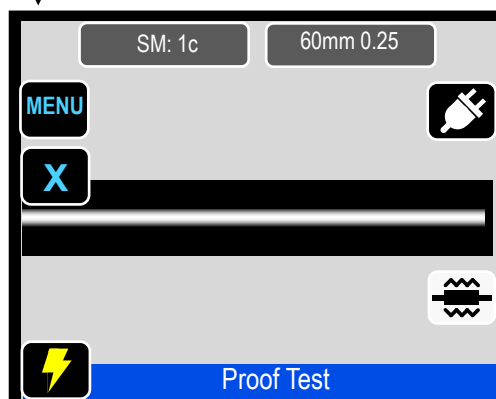

The proof test is started.
(The test cannot be canceled once started.)

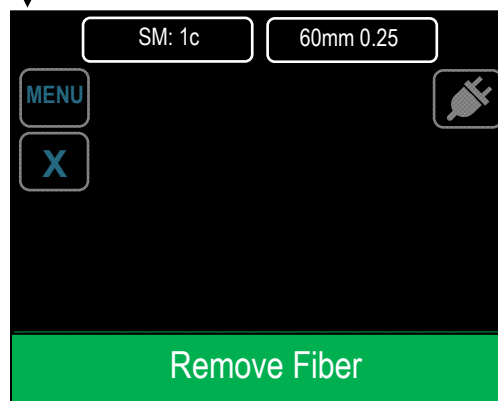

Open the hood and remove the spliced fiber when the screen above is displayed.

Take care to keep the spliced fiber straight. Do not flex it back and forth. Doing so will cause the spliced fiber to be broken, resulting in loss of the long term reliability of the fiber.

Evaluating splice quality

If the spliced fiber is as follows or estimated losses are high, re-do the entire splice.

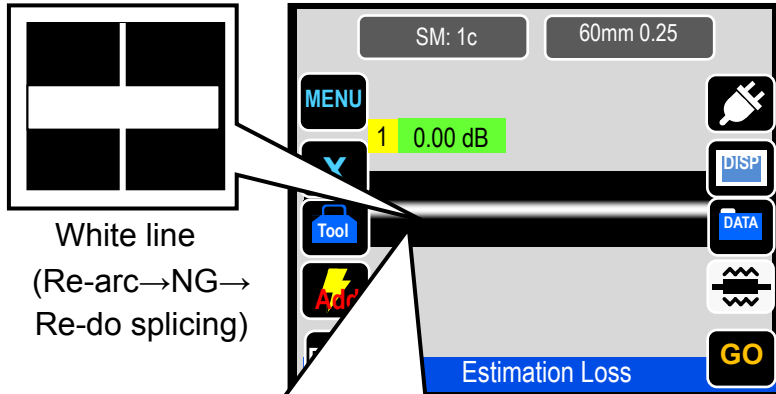

Bulging

(Re-do splicing.)



Neck-down

(Re-do splicing)

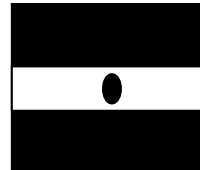

Bubble

(Re-do splicing.)



Black line

(Re-do splicing.)

After MMF or dissimilar fiber splicing, a line sometimes appears at the splice point. But it does not affect splice quality, such as splice loss, tensile strength, and etc.

Splice protection

- 1: Open the heat shrink oven lid and the heat shrink oven clamps.
Open the hood and the fiber coating clamps to release the spliced fiber.
- 2: Make sure that the fiber protection sleeve is centered over the spliced portion of the fiber.

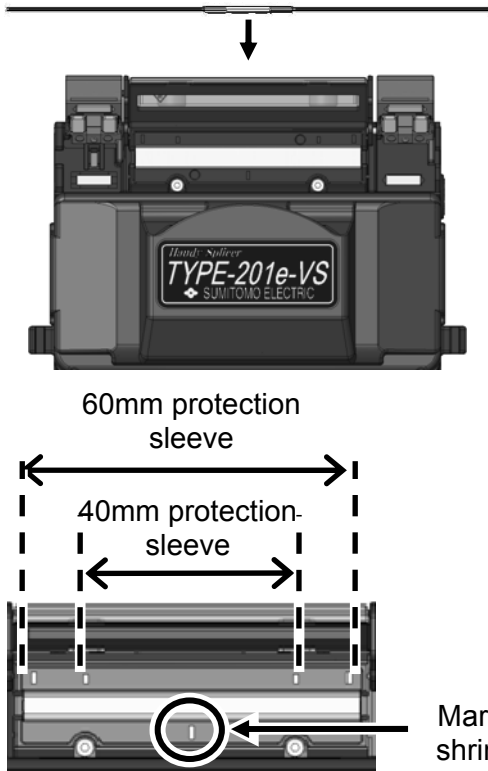

The applicable fiber protection sleeves vary depending on the cleave length. For more information, refer to page 1-5.

- 3: While maintaining a slight tension on the fiber end, lower the fiber onto the heat shrink oven and push down.

- Do not twist the fiber.
- Do not flex the fiber.

- 4: Close both oven clamps and the oven lid.

When lowering the fiber onto the heat shrink oven, use the markings on the heat shrink oven as a reference.

- 5: Touch “heat” icon () on the screen.

The heat cycle is started.

If Auto start heating is set to ON, the heating operation is automatically started when the fiber is placed into the heat shrink oven.

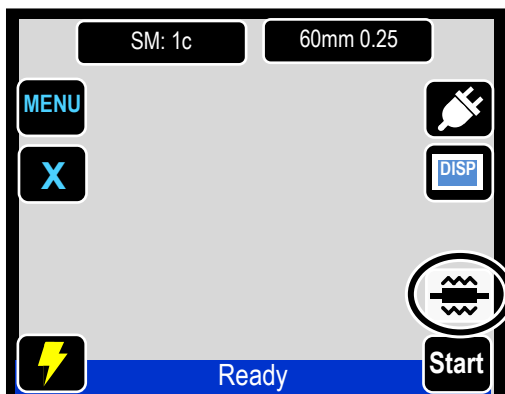

The heat icon changes as follows.

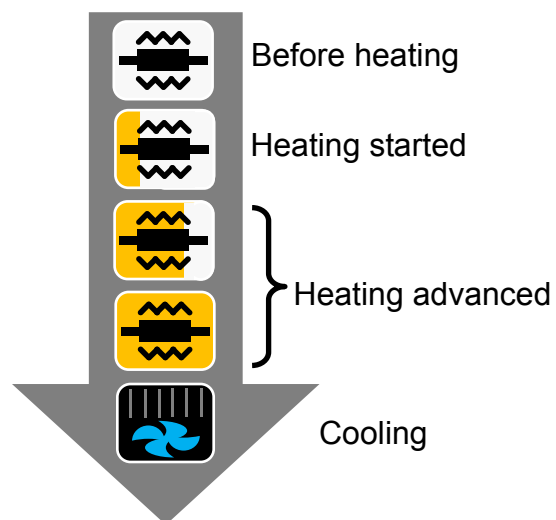

To cancel the heat shrink process, touch the heat icon () again.

- 6: The splicer gives a beep sound indicating completion of the heating cycle. Take out the sleeve from the heat shrink oven after a beep sound is heard.
- 7: Place the protection sleeve onto the cooling tray.



Caution

The protection sleeve can be taken out from the heat shrink oven after a beep sound is heard. Also finish of heating cycle can be confirmed by the heat icon's change. If the sleeve is taken out from the oven before heat cycle completed, the splice loss might increase because the less cooling cause fiber bending or twisting. Please wait for the finish of heating cycle.

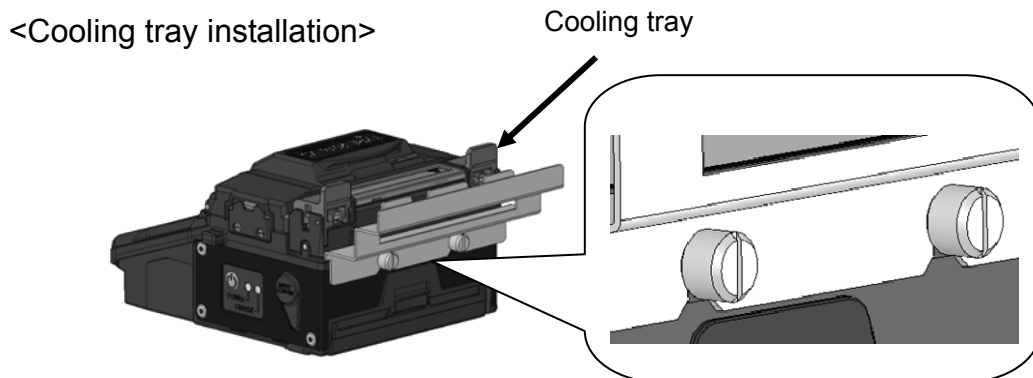

- 1: Tighten the hand screws temporarily.
- 2: Fit the cooling tray to the splicer. (See the drawing above.)
- 3: Tighten the hand screws a bit more to hold the cooling tray in place.





Caution

After the heat cycle is complete, the fiber protection sleeve may be hot. Handle with care.
Never touch the surface of the heating plate during the heating operation. Doing so may cause personal injury and damage to the heat shrink oven.

Evaluating protection sleeve

NG

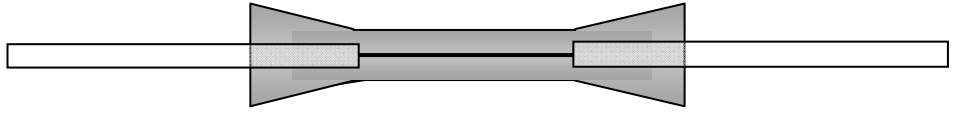
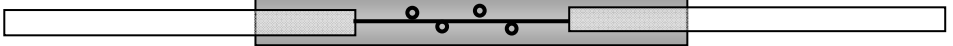
- 1: The shrinking sleeve is not centered over the splice.
 
- 2: Bend in bare fiber
 
- 3: Incompletely shrunk (trumpet end)
 
- 4: Bubbles on bare fiber
 

Drop cable splicing

Removing cable sheath

The TYPE-201e-VS/M4 can achieve splicing of drop/small-sized indoor cable fiber. This section outlines procedures on how to remove cable sheath.

Clean the cable sheath thoroughly to remove cable gel or other stains.



1. Separate the steel wire from the cable using nippers.



2. Cut the steel wire to a desired length.

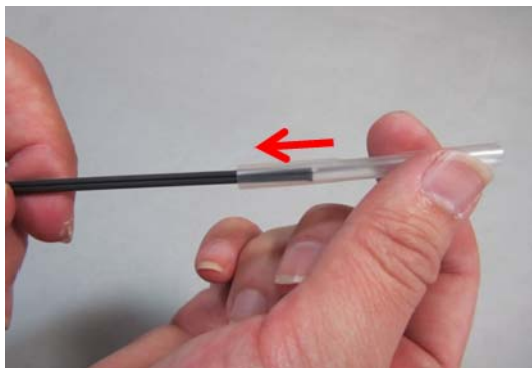

3. Insert a protection sleeve over the cable.



4. Make a slit along the groove of the cable sheath using nippers.

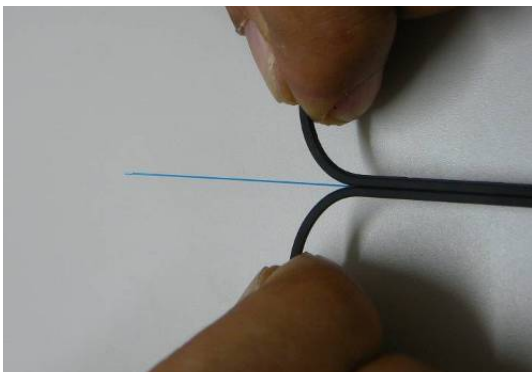

5. Split the cable sheath to expose 30~40mm of optical fiber. Cut off the split cable sheath.

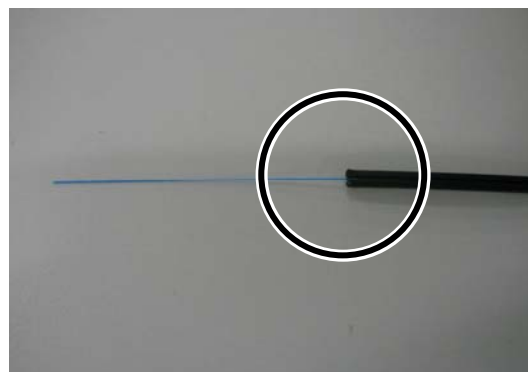

6. The cable sheath is removed. Repeat step 1 to 5 for the other cable.



Take care not to damage the optical fiber when cutting the cable sheath.



Cut each half of the cable sheath to the same length.

Fiber preparation procedures

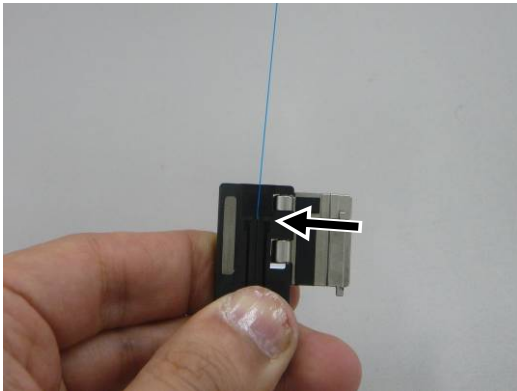

1. Load the cable with its sheath removed in the fiber holder. Make sure that the cable sheath touches the groove. Close the bigger lid of the holder first.

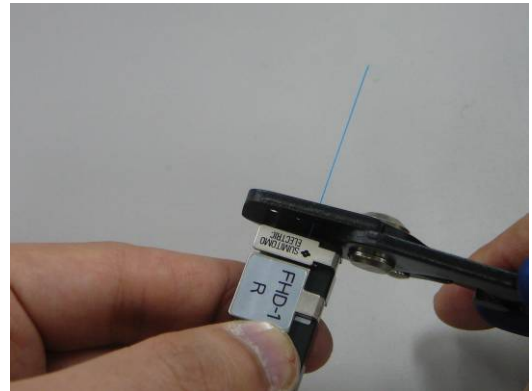

2. Remove the fiber coating at 2~4mm away from the edge of the fiber holder. (Touch the JR-M03 against the edge to remove, and you can remove the coating at 3mm away from the edge.)



3. Clean the bare fiber from the end of the fiber coating with a gauze pad moistened with pure alcohol. Pull the bare fiber through the gauze pad and rotate the fiber to remove any coating residue.

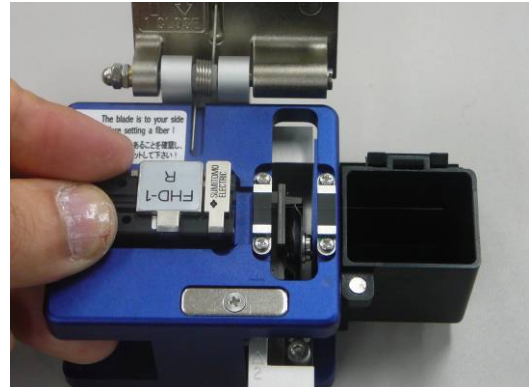

4. Place the fiber holder in the cleaver, touching the edge of the fiber holder against the edge of the fiber holder receptacle. Cleave the fiber referring to the cleaver instructions.

5. Repeat step 1~4 for the other cable.
6. Place the fiber holder in the splicer and start the splicing process.
(Note: Perform an arc test prior to splicing.)



Inserting the fiber into the splicer

1. Open the hood.
2. Place the fiber holder onto the fiber holder stage, fitting the pin of the stage into the hole of the fiber holder.



Take great care not to touch the fiber end face against any surfaces.

3. Make sure that the fiber sits in the V-groove correctly.

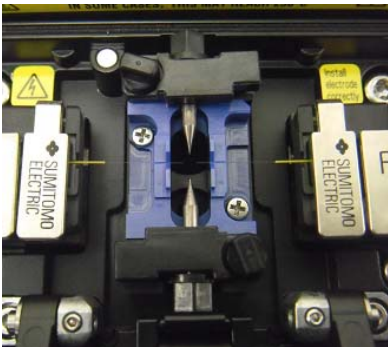

4. Close the hood.
5. Start the splicing process.
(Note: Perform an arc test prior to splicing.)

Splice protection

1. Open the oven lid and oven clamps. Open the hood and all lids of the fiber holders.
2. Take out the cable and slide the fiber protection sleeve onto the fiber. Make sure that the protection sleeve is centered over the splice and at least 5mm of the sleeve overlaps the cable sheath at each end of the splice.

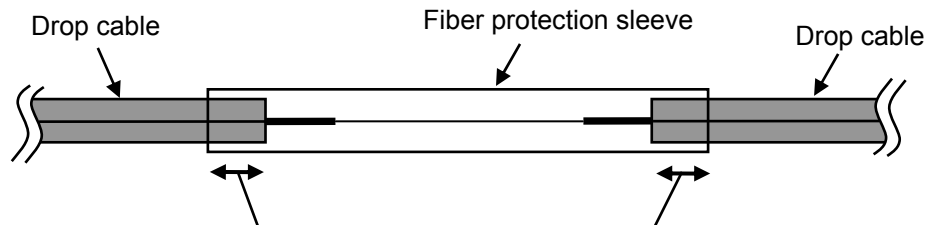

At least 5mm of the sleeve must overlap the cable sheath at each end of the splice.

3. While maintaining a slight tension on the cable ends, transfer the cable to the heat shrink oven and close the right hand oven clamp.



Caution

Pay attention not to bend and flex the cable. Failure to do so can cause the splice to break.

4. While applying a slight tension to the cable end, close the left hand oven clamp and oven lid. Start the heat shrink process.

5. After the heat shrink process is complete, open the oven lid and oven clamps and take out the cable.



While maintaining a slight tension on the cable ends, close the oven clamps.

3. Daily cleaning and checking up

To keep excellent splice quality, regular cleaning and inspection are required. Especially cleaning should be performed before and after each use. We recommend your splicer to be checked through our maintenance service once a year.



Turn off the TYPE-201e-VS/M4 before maintenance work. Failure to do so may cause electric shock.

Cleaning

Clean each part with a cotton swab. Please bear in mind that daily cleaning can maintain splicer performance. Clean components before and after use.

Names of components

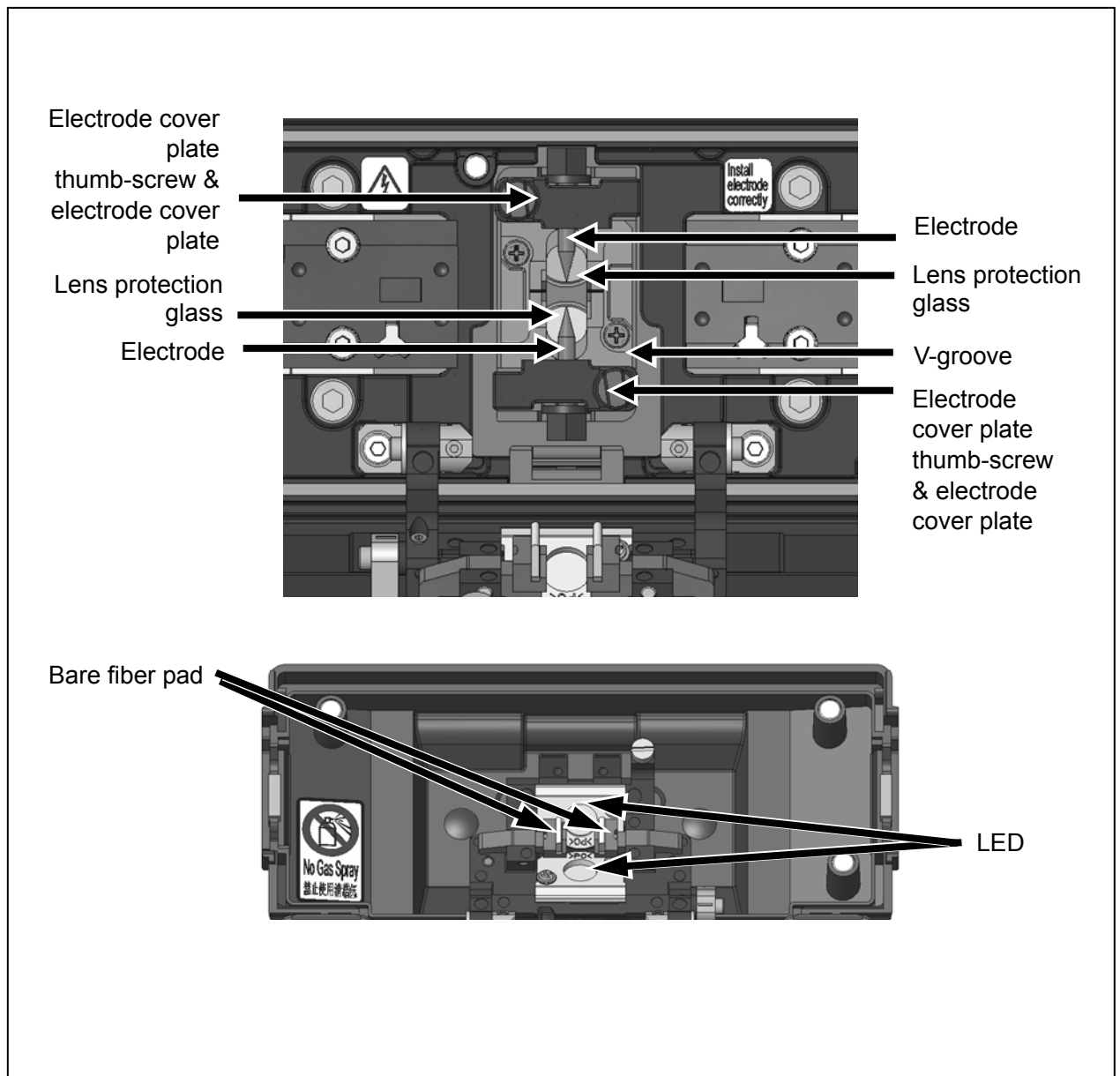

Cleaning V-grooves

Even tiny bits of dust or dirt in the V-grooves might cause the fiber to be offset. To avoid offset, carefully clean the V-grooves with a cotton swab moistened with alcohol.

1: Prepare a V-groove cleaning brush or cotton swab moistened with alcohol.

2: Brush the surface of the V-grooves in the direction indicated by the arrow.

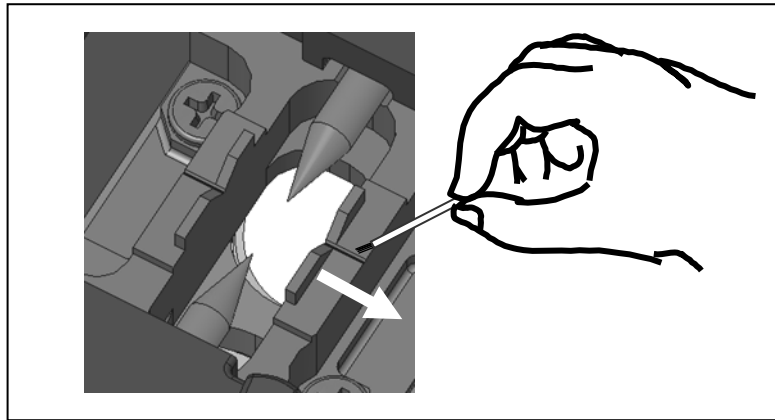

Cleaning bare fiber pads

Dirt on a bare fiber pad will also cause the fiber to be offset. When fiber offset occurs, clean the bare fiber pad.

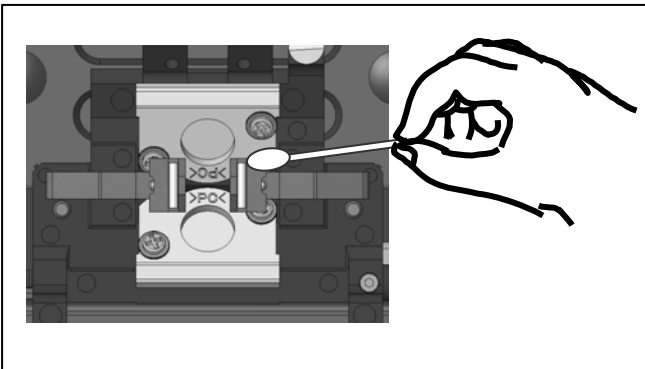

Do not apply too much force when cleaning.

1: Prepare a cotton swab moistened with alcohol and wipe the surface of bare fiber pads.

2: Use a dry cotton swab to wipe off any excess alcohol.

Cleaning LEDs

When a LED surface is dirty, a fiber image is unclear, resulting in imperfect image processing. If the display is uneven or LED error occurs, clean them with a cotton swab moistened with alcohol.

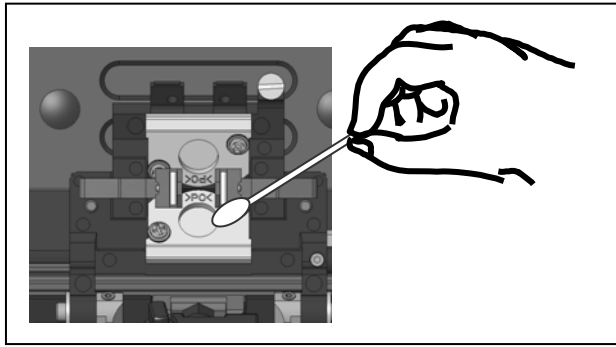

- 1: Prepare a cotton swab moistened with alcohol and wipe the surface of LED
- 2: Use a dry cotton swab to wipe off any excess alcohol.

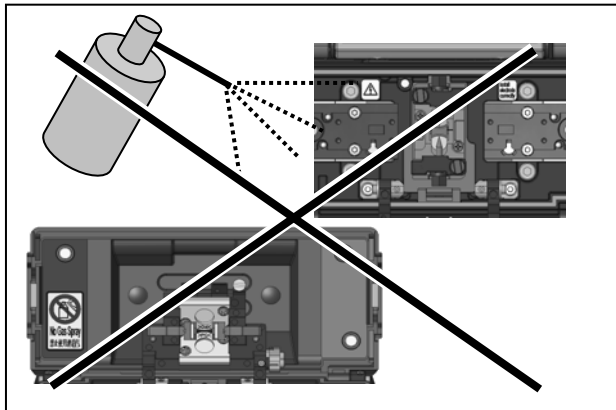

Prohibition

Do not use a canned air for cleaning. Chemical reaction may deteriorate the LED, resulting in a loss of splicing capability.

Cleaning microscope objective lens

If an unclear fiber image is still displayed or LED error occurs again after the LED is cleaned, the microscope objective lens should be cleaned.

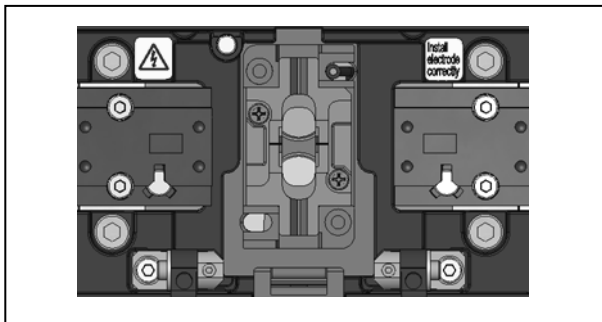

- 1: Remove the electrodes, referring to the "Replacing electrodes".

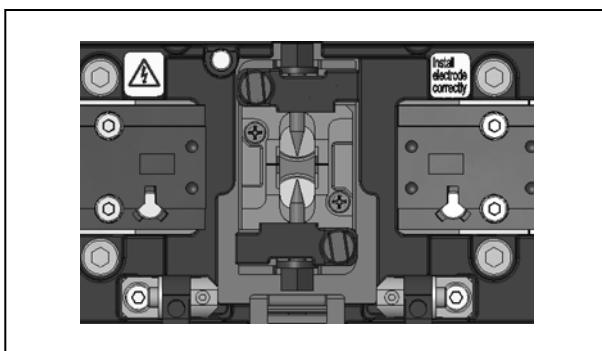
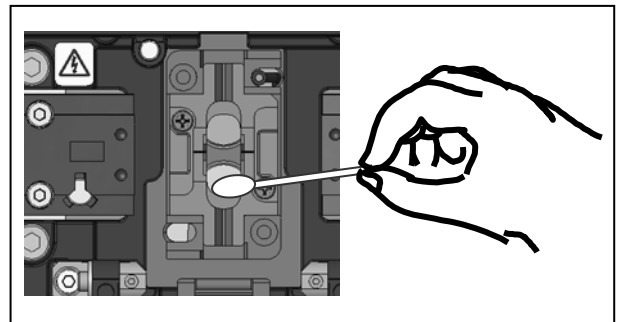

- 2: Prepare a cotton swab moistened with alcohol.
- 3: Gently wipe the lens protection glass in a circular motion.
- 4: Use a dry cotton swab to wipe off any excess alcohol.
- 5: Re-fit the electrodes.
- 6: Perform an arc test.

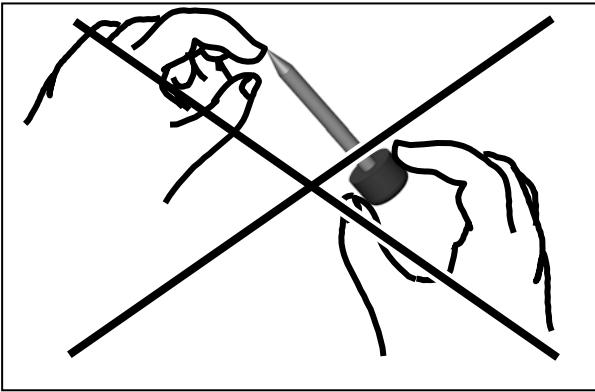

An electrode tip is extremely sharp.
Handle with care.

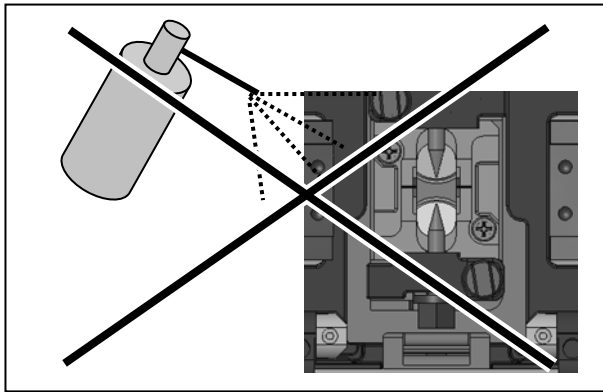

Prohibition

Do not use a canned air for cleaning.
Chemical reaction may deteriorate the
lens protection glass, resulting in a loss
of splicing

Cleaning heat shrink oven

Dirt and dust can accumulate in the heat shrink oven easily. Clean the heating plate regularly with a dry cotton swab.

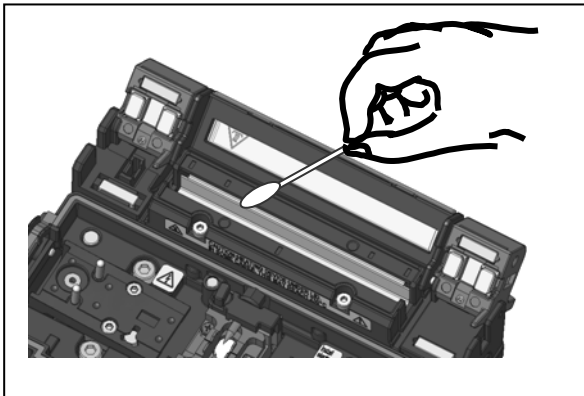

Clean the heating plate with a dry cotton swab.

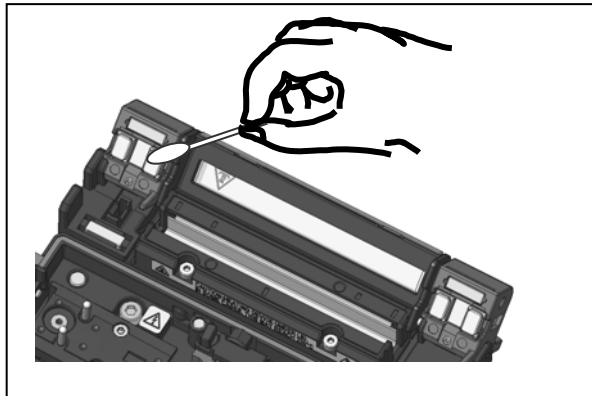

Clean the clamps of the heat shrink oven with
a cotton swab moistened with alcohol.



Caution

Remove moisture or alcohol on the heat shrink oven with a dry
cotton swab.

Cleaning fiber holders

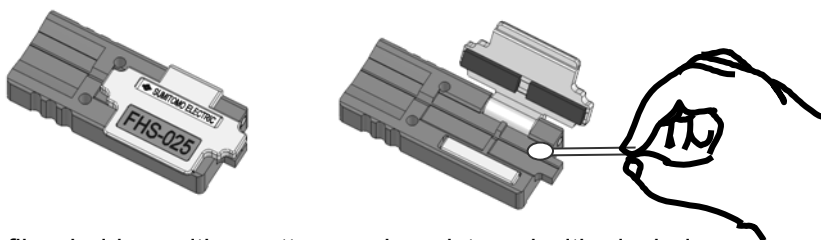

Clean the fiber holders with a cotton swab moistened with alcohol.

Replacing electrodes

Electrodes are worn out or contaminated due to silica glass evaporated during arc, and the electrode condition changes day by day. To achieve a repetitive and stable arc for excellent quality splicing, electrodes should be replaced periodically. Continuing to use the same electrodes may result in high splice losses and poor splice strength.

On the TYPE-201e-VS, electrodes typically need replacing after approximately 3,000 arc discharges.

If the number of arc discharge exceeds 2,500, Arc Count on the screen will be highlighted in yellow for warning, with a message “Electrode need changing soon”.

If the number exceeds 3,000 times, a warning message appears every time the splicer is powered on and until you replace electrodes according to the replacement procedures described in the next page.

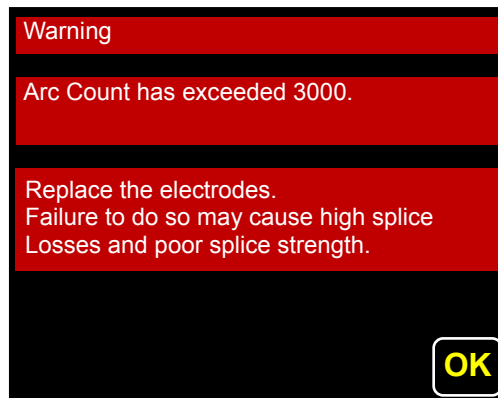

On the TYPE-201e-M4, electrodes typically need replacing after approximately 1,500 arc discharges.

If the number of arc discharge exceeds 1,200, Arc Count on the screen will be highlighted in yellow for warning, with a message “Electrodes need changing soon”.

If the number exceeds 1,500 times, a warning message appears every time the splicer is powered on and until you replace electrodes according to the replacement procedures described in the next page.

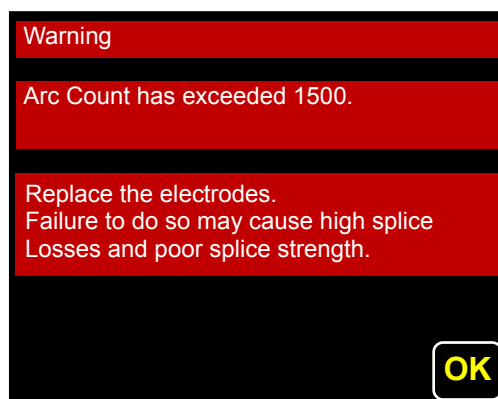

Electrode replacement procedures

To keep the excellent performance of the TYPE-201e-VS/M4, replace electrodes with new ones after 1,500 arc discharges for the TYPE-201e-M4, and after 3,000 arc discharges for the TYPE-201e-VS. The tip of an electrode is extremely sharp. Handle with care



1: Turn off the splicer and unplug the power cord.

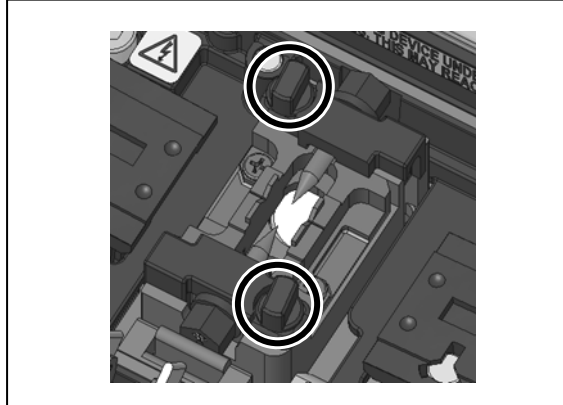

2: Using your fingers, loosen the thumbscrews.

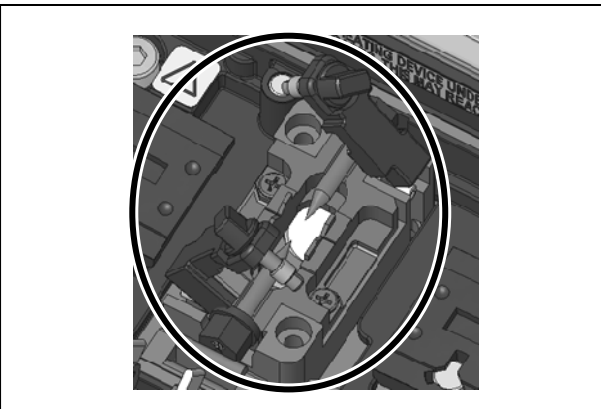

3: Lift the electrode cover plate as shown in the left figure.

4: Remove the old electrode.

5: Install a new electrode.



Caution

When handling the electrodes, avoid touching the electrode tips with anything.

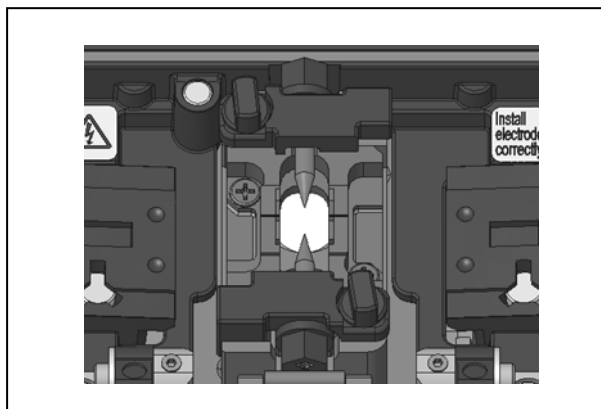

6: Tighten the thumbscrew while pressing the electrode below at each electrode cover plate.

7: Repeat step 2 to 5 for the other electrode. Always replace both electrodes at a time.

8: Plug the power cord into the splicer and turn on the power to condition the electrodes. (Refer to page 4-9.) After conditioning the electrodes, the Arc count is automatically reset.

Always replace with Sumitomo genuine electrodes in pairs at a time. Failure to do so can keep the splicer from maximizing its ability.

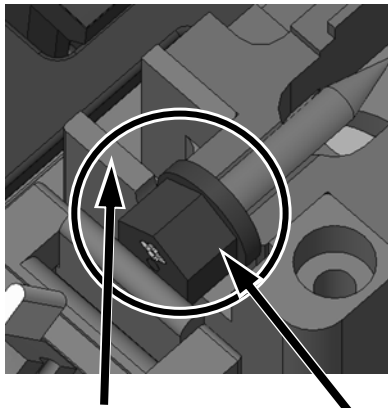

Protrusion

Plastic button



Caution

Make sure the plastic button of the electrode is certainly pushed against the protrusion.

<OK>

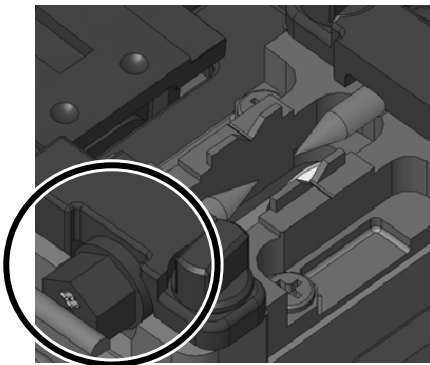

<NG>

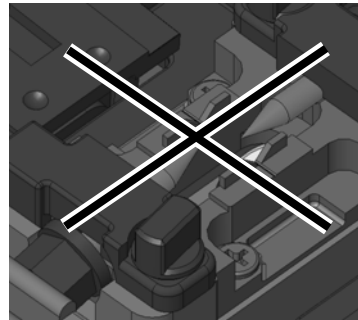

Caution

Splice performance will be unstable or a part of the splicer is damaged if electrodes are not installed in place correctly

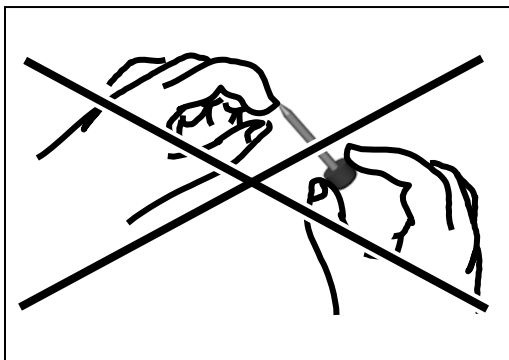

Caution

An electrode tip is extremely sharp. Handle with care.



Caution

- Be sure to turn off the splicer and unplug the power cord or remove the battery pack before replacing the electrodes.
- Discard the old electrodes properly.



Caution

- Do not clean the electrode. Doing so may cause unstable arcing performance.

Packing and storage instructions

- Store the TYPE-201e-VS/M4 and its accessories in a designated place in the case referring to the photo below.
- Store the TYPE-201e-VS/M4 in the direction shown in the photo below.
- The TYPE-201e-VS/M4 with a cooling tray cannot be stored in the case. Remove the cooling tray from the splicer and store it in the pocket.

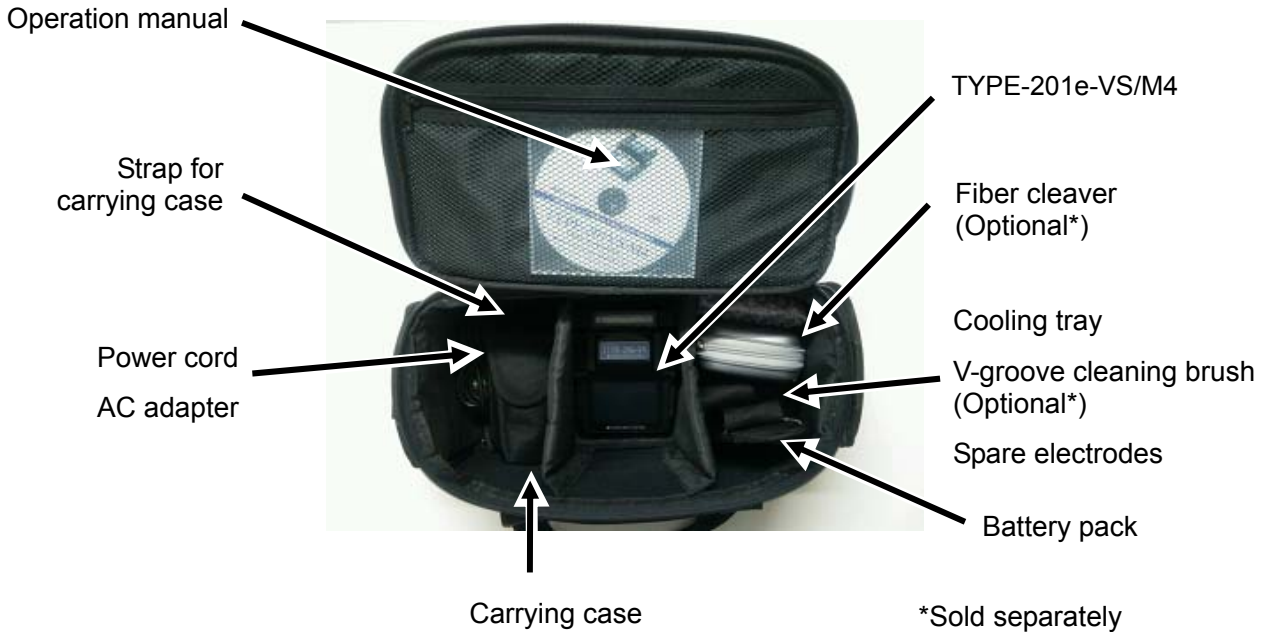

Packing example (CCS-25)

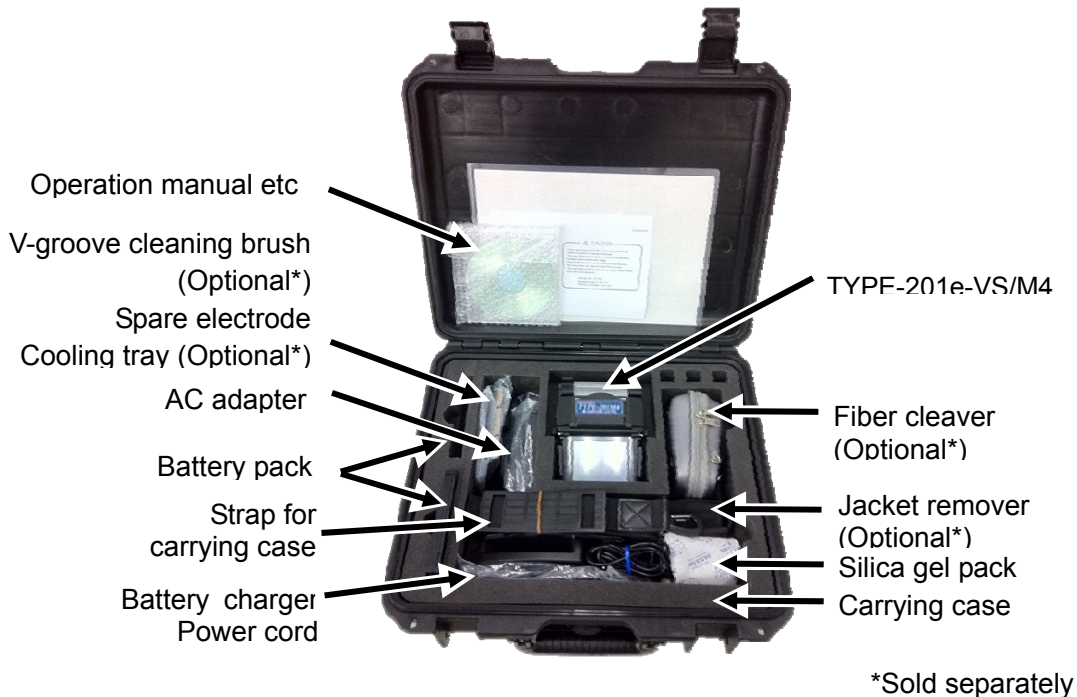

Packing example (CCT-201)

The fusion splicer is a precision instrument. Its rugged shipping case is custom designed to protect it from impact, dust, dirt, and moisture. Always store and transport the machine in its case. Observe the following instructions.

- Clean the TYPE-201e-VS/M4 and all accessories before storing them.
- Be sure to remove the battery pack from the TYPE-201e-VS/M4 and store it in a given place.



Keeping the battery in the TYPE-201e-VS/M4 may cause the battery terminal to be damaged or deteriorated, resulting in fire.

- Discard the liquid solvent properly, or lock the dispenser completely and put it in a plastic bag before packing the dispenser in the case.



Take extreme care of the handling of alcohol.

- Before storing the fiber cleaver, dispose of the fiber fragments collected in the off-cut collector in a proper way.



Glass fiber fragments are extremely sharp. Handle with care.

- Close the carrying case completely and latch it before transportation.
- Pay attention to storage temperature and dew condensation when storing the splicer. The battery is self-discharged during storage. Perform temperature control and charge and discharge the battery once every 6 months.

Storage temperature -20°C ~ +50°C (if stored for less than 1 month)
-20°C ~ +40°C (if stored for less than 3 months)
-20°C ~ +20°C (if stored for less than 1 year)

4. Functions

Splice and heater programs setting

<Splice program setting>

*The example below shows use of TYPE-201e-M4.

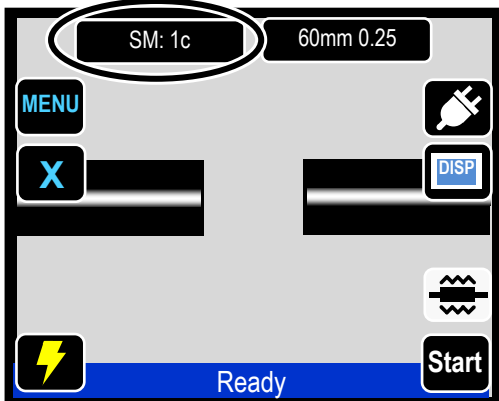

Touch the splice program icon once. The icon will expand. Then touch it again.

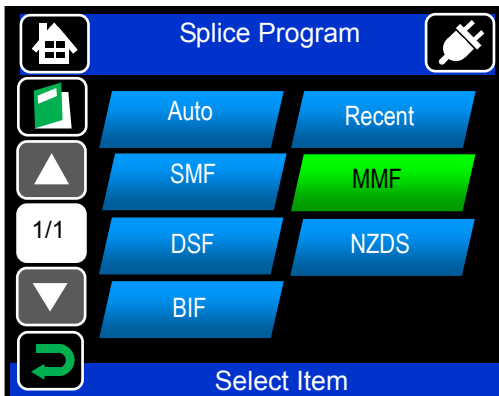

Select the category of the fiber.

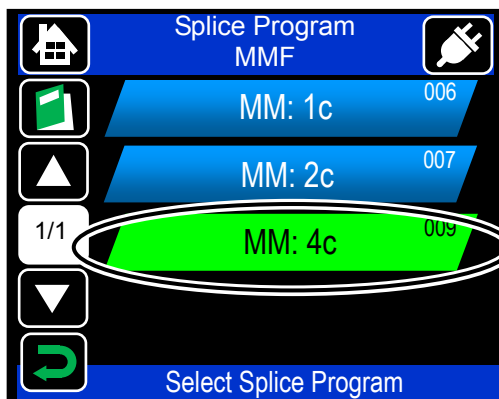

Touch splice program once. The icon will be highlighted in light green. Touch it once more to confirm the selection.

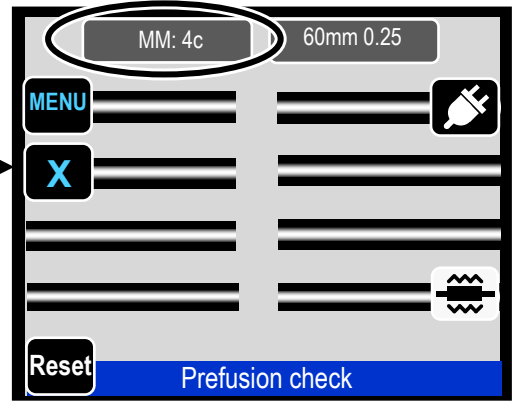

Splice program is changed.

For the details of splice programs, refer to page 4-3.

If you would like to change splicer program parameters, refer to page 4-6.

<Heater program setting>

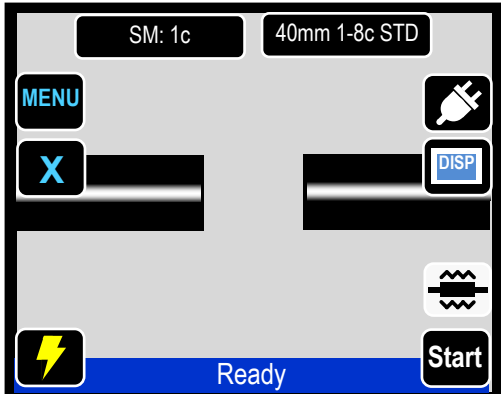

Touch the heater program icon once. The icon will expand. Then touch it again.

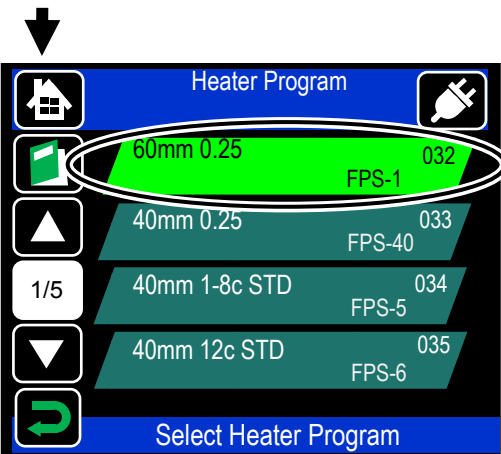

Touch heater program once. The icon will be highlighted in light green. Touch it once more to confirm the selection.

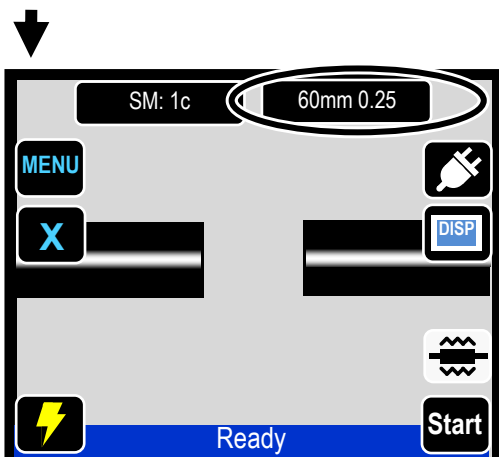

Heater program is changed.

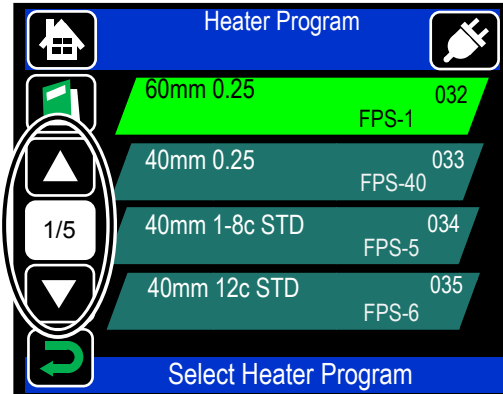

If the page icon ($\frac{x}{x}$) displays the number except "1/1", that means there are more pages. Touch the "move" (\blacktriangle , \blacktriangledown) or the page icon to go to the next pages.

For the details of heater programs, refer to page 4-4.
If you would like to change heater program parameters, refer to page 4-6.

Splice programs

Category	Splice Program	Details	VS	M4
Auto	SM : Auto	Used to splice identical standard SMF (ITU-T G.652).	○	○
	MM : Auto	Used to splice identical standard MMF (ITU-T G.651).	○	○
	DS/NZ: Auto	Used to splice identical standard DSF (ITU-T G.653), NZDSF (ITU-T G.655).	○	○
Recent	---	Displays recently selected splice program.	○	○
SMF	SM : 1c	Used to splice identical standard single SMF (ITU-T G.652).	○	○
	SM : 2c	Used to splice identical standard 2 count ribbon SMF (ITU-T G.652).	---	○
	SM : 4c	Used to splice identical standard 4 count ribbon SMF (ITU-T G.652).	---	○
MMF	MM : 1c	Used to splice identical standard single MMF (ITU-T G.651).	○	○
	MM : 2c	Used to splice identical standard 2 count ribbon MMF (ITU-T G.651).	---	○
	MM : 4c	Used to splice identical standard 4 count ribbon MMF (ITU-T G.651).	---	○
DSM	DSM : 1c	Used to splice identical standard single DSF (ITU-T G.653).	○	○
	DSM : 2c	Used to splice identical standard 2 count ribbon DSF (ITU-T G.653).	---	○
	DSM : 4c	Used to splice identical standard 4 count ribbon DSF (ITU-T G.653).	---	○
NZDS	NZDS : 1c	Used to splice identical standard single NZDSF (ITU-T G.655).	○	○
	NZDS : 2c	Used to splice identical standard 2 count ribbon NZDSF (ITU-T G.655).	---	○
	NZDS : 4c	Used to splice identical standard 4 count ribbon NZDSF (ITU-T G.655).	---	○
BIF	BIF : 1c	Used to splice identical standard single BIF (ITU-T G.657).	○	○

*1: In Auto mode, the splicer automatically detects the fiber count loaded and selects a suitable splice program for the fiber count. As it automatically optimizes arc power every fusion splice, normally it is not necessary to perform an arc test.

*2: Perform an arc test before splicing if using splice programs other than Auto mode.

Heater programs

Heater programs are optimized for Sumitomo protection sleeves. Select an appropriate heater program for the protection sleeve you use.

Heater program	Details	VS	M4
60mm 0.25 FPS-1	Used to heat shrink standard 60mm protection sleeves for 0.25mm coated single fiber. Best suitable program for Sumitomo FPS-1.	○	○
40mm 0.25 FPS-40	Used to heat shrink standard 40mm protection sleeves for 0.25mm coated single fiber. Best suitable program for Sumitomo FPS-40.	○	○
40mm1-8c STD FPS-5	Used to heat shrink standard 40mm protection sleeves for single fiber and up to 8 fiber ribbon. Best suitable program for Sumitomo FPS-5.	○	○
40mm 12c STD FPS-6	Used to heat shrink standard 40mm protection sleeves for single fiber and up to 12 fiber ribbon. Best suitable program for Sumitomo FPS-6.	○	○
40mm 1-8c FPS-5	Used to heat shrink standard 40mm protection sleeves for single fiber and up to 8 fiber ribbon.	○	○
S60mm 0.25 FPS61-2.6	Used to heat shrink standard 60mm semi pre-shrunk protection sleeves. Best suitable program for Sumitomo FPS-61-2.6.	○	○
S40mm 0.25 FPS40-2.6	Used to heat shrink standard 40mm semi pre-shrunk protection sleeves. Best suitable program for Sumitomo FPS-40-2.6.	○	○
S60mm0.25+5s FPS61-2.6	Program where the heating time for “S60mm 0.25” program is increased by 5 seconds.	○	○
S60mm0.25-5s FPS61-2.6	Program where the heating time for “S60mm 0.25” program is decreased by 5 seconds.	○	○
S40mm0.25+5s FPS40-2.6	Program on which the heating time for “S40mm 0.25” program is increased by 5 seconds.	○	○
S40mm0.25-5s FPS40-2.6	Program on which the heating time for “S40mm 0.25” program is decreased by 5 seconds.	○	○
60mm 0.9 FPS-1	Used to heat shrink standard 60mm protection sleeve for 0.9mm coated single fiber. Best suitable program for Sumitomo FPS-1.	○	○
40mm 0.9 FPS-40	Used to heat shrink standard 40mm protection sleeves for 0.9mm coated single fiber. Best suitable program for Sumitomo FPS-40.	○	○
LYNX	Used to heat shrink dedicated protection sleeves for Sumitomo splice-on-connector “Lynx-CustomFit”.	○	○
LYNX MINI	Can be used for heat shrinking protection sleeves for 5mm cleaved Sumitomo’s splice-on-connector “Lynx-CustomFit”.	○	---
Drop FPS-D60	Used to heat shrink 60mm protection sleeve for drop cable. Best suitable program for Sumitomo FPS-D60.	○	○

Heater program	Details	VS	M4
40mm 0.4 FPS-N4-40	Can be used for heat shrinking 40mm protection sleeves of Nano Sleeves N4 series, for example, Sumitomo FPS-N4-40.	○	○
25mm 0.4 FPS-N4-25	Can be used for heat shrinking 25mm protection sleeves of Nano Sleeves N4 series, for example, Sumitomo FPS-N4-25	○	---
20mm 0.4 FPS-N4-20	Can be used for heat shrinking 20mm protection sleeves of Nano Sleeves N4 series, for example, Sumitomo FPS-N4-20	○	---
25mm 0.9 FPS-N9-25	Can be used for heat shrinking 25mm protection sleeves of Nano Sleeves N9 series, for example, Sumitomo FPS-N9-25.	○	---
20mm 0.9 FPS-N9-20	Can be used for heat shrinking 20mm protection sleeves of Nano Sleeves N9 series, for example, Sumitomo FPS-N9-20.	○	---

<Change splice program parameter>

*The example below shows use of TYPE-201e-M4.

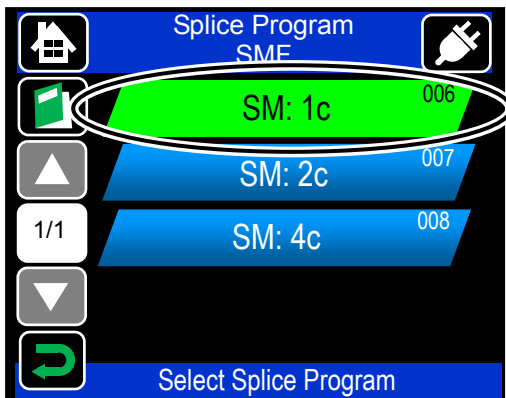

In the splice program setting screen (page 4-1), select the program (highlighted), then touch “Setting” icon (). Item select screen is displayed.

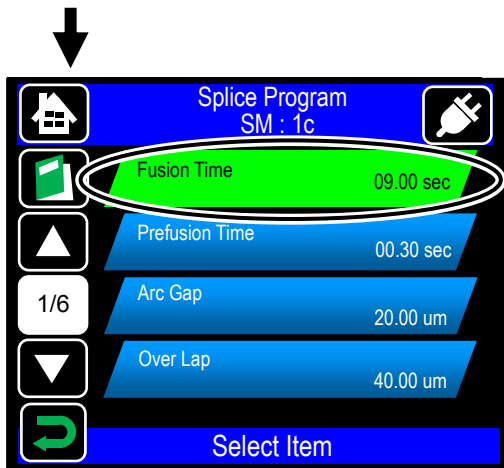

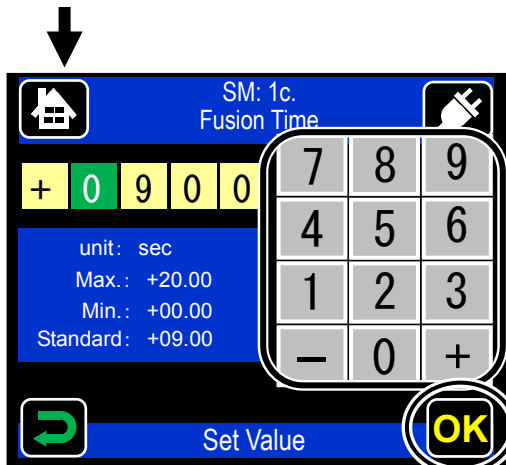

Touch the item you'd like to change once. The icon will be highlighted in light green. Touch it once more to confirm.

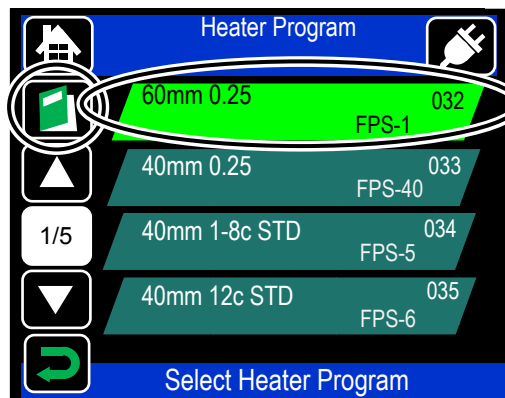

Input the value by touching number keys. Touch “OK” ().

<Change heater program parameter>



In the heater program setting screen (page 4-2), select the program (highlighted), then touch “Setting” icon (). Item select screen is displayed.

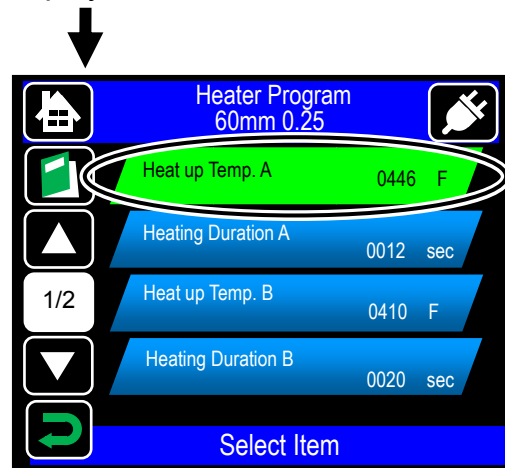

Touch the item you'd like to change once. The icon will be highlighted in light green. Touch it once more to confirm.

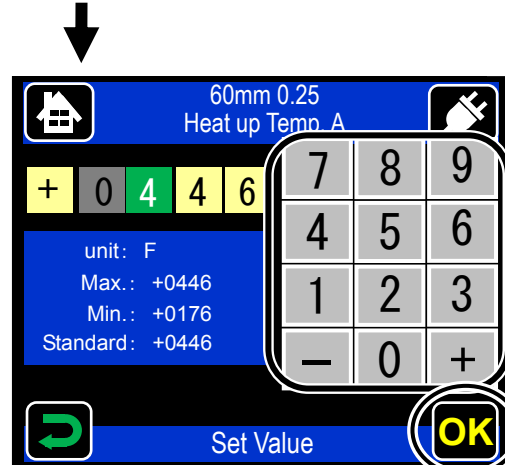

Input the value by touching number keys. Touch “OK” ().

Page	Splice program items
1/2	<Fusion Time>
	Fusion time is the duration of arc discharge. (Numerical input)
	<Prefusion Time>
	Pre-fusion time is the time in seconds the fiber ends wait after the arc discharge begins before beginning the overlap (feed). (Numerical input)
	<Arc Gap>
	Arc gap is the distance between the left and right fibers before fusion takes place. (Numerical input)
	<Over Lap>
Overlap is the amount of overlap between the left and right fibers that occurs when the right fiber is fed forward during the arc fusion. (Numerical input)	
2/2	<Arc Power>
	Expressed in a unit-less step value as [Standard +XX]. Arc power controls the amount of heat the fibers are exposed to during the fusion arc. As the power is automatically set after an arc test and compensated at every splices, normally an operator does not need to change it manually. "Standard" means compensated arc power of the splice program, and added value can be manually set by operator. (Numerical input)
	<Arc Center>
	Arc center is the position of the arc center. Usually it is set automatically by the splicer. (Numerical input)

Page	Heater program items
1/2	<Heat up Temp A>
	Heating element rise up to the set temperature in the first term of heating cycle. (Numerical input)
	<Heating Duration A>
	Duration of the first term of heating cycle. (Numerical input)
	<Heat up Temp B>
	Heating element rise up to the set temperature in the middle term of heating cycle. (Numerical input)
2/2	<Heating Duration B>
	Duration of the middle term of heating cycle. (Numerical input)
	<Finish Temp>
	The temperature of finishing heating cycle after cooling by the fan. (Numerical input)

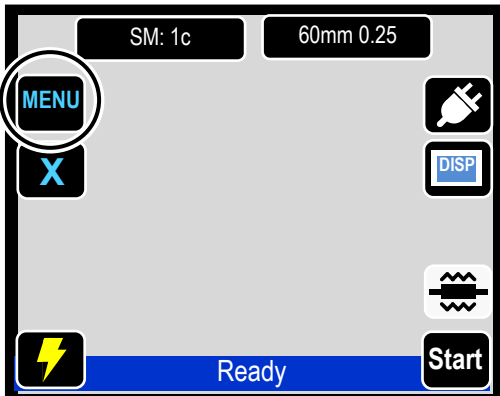

Touch "Menu" () to go to menu screen.

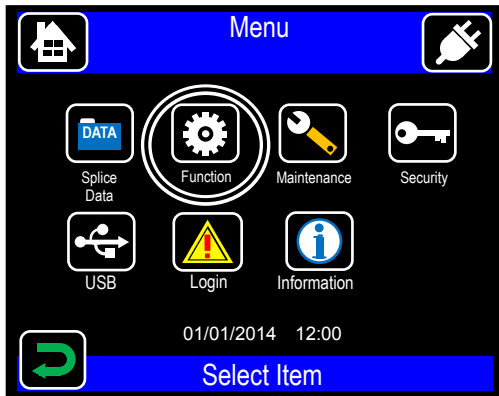



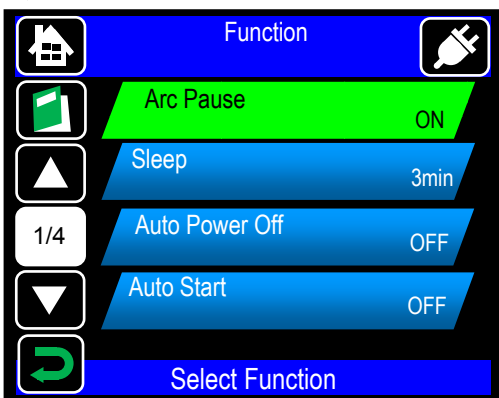

Touch "Function" () to go to function screen.

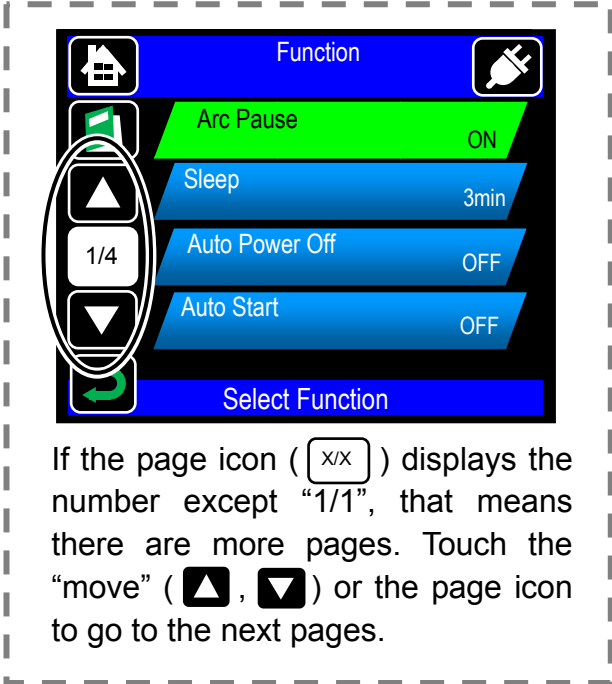

Touch the item once. The icon will be highlighted in light green. Then touch it again to go to setting screen.

For more details of the items of function, please refer to the page 4-9.



If the page icon () displays the number except "1/1", that means there are more pages. Touch the "move" ( , ) or the page icon to go to the next pages.

Page	Functions
1/4	<p data-bbox="357 208 1503 246" style="text-align: center;"><Arc Pause></p> <p data-bbox="357 253 1503 331">This function stops the splicing process before arcing occurs. If you would like to check offset and fiber end faces, set this function to ON.</p> <p data-bbox="357 338 1503 376" style="text-align: center;"><Sleep></p> <p data-bbox="357 383 1503 544">If the splicer is not interrupted for a certain span of time, to minimize power consumption on standby, the monitor and 12VDC will be turned off. (The Power LED will be lit in orange.) To return to normal operation, press any key, except the Power key.</p> <p data-bbox="357 551 1503 589" style="text-align: center;"><Auto Power Off></p> <p data-bbox="357 595 1503 674">If the splicer is in Sleep mode and is not interrupted for another certain span of time, the splicer is automatically powered off. You need to switch on the splicer again.</p> <p data-bbox="357 680 1503 719" style="text-align: center;"><Auto Start></p> <p data-bbox="357 725 1503 804">This function starts the splicing process when the fiber is inserted in the splicer and the hood is closed.</p>
2/4	<p data-bbox="357 817 1503 855" style="text-align: center;"><Language></p> <p data-bbox="357 862 1503 940">The language being displayed can be selected. (Some languages cannot be selected.)</p> <p data-bbox="357 947 1503 985" style="text-align: center;"><Temperature Unit></p> <p data-bbox="357 992 1503 1030">This function switches the temperature units.</p> <p data-bbox="357 1037 1503 1075" style="text-align: center;"><Heater Auto Start></p> <p data-bbox="357 1081 1503 1160">This function starts the heating process when the fiber is placed into the heat shrink oven.</p> <p data-bbox="357 1167 1503 1205" style="text-align: center;"><Date></p> <p data-bbox="357 1211 1503 1249">This function sets the built-in clock of the splicer to local time.</p>
3/4	<p data-bbox="357 1254 1503 1292" style="text-align: center;"><Buzzer (Key)></p> <p data-bbox="357 1299 1503 1377">Buzzer sound of touching icons or pressing keys can be selected. "Mute" can be selected too.</p> <p data-bbox="357 1384 1503 1422" style="text-align: center;"><Buzzer (Stop)></p> <p data-bbox="357 1429 1503 1467">Buzzer sound of arc pause can be selected. "Mute" can be selected too.</p> <p data-bbox="357 1473 1503 1512" style="text-align: center;"><Buzzer (Error)></p> <p data-bbox="357 1518 1503 1556">Buzzer sound of detecting errors during splice. "Mute" can be selected too.</p> <p data-bbox="357 1563 1503 1601" style="text-align: center;"><Bright></p> <p data-bbox="357 1608 1503 1646">The brightness of the monitor can be adjusted by eight stages.</p>
4/4	<p data-bbox="357 1657 1503 1695" style="text-align: center;"><Audio Volume></p> <p data-bbox="357 1702 1503 1740">The volume of the speaker can be adjusted by four stages.</p>

Maintenance settings

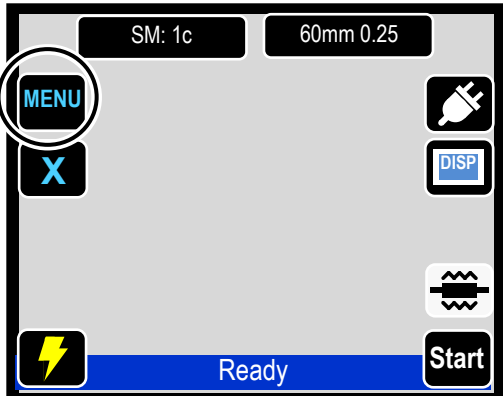

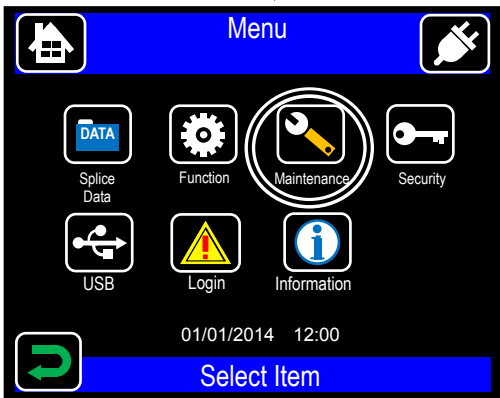

Touch "MENU" () to go to Menu screen.

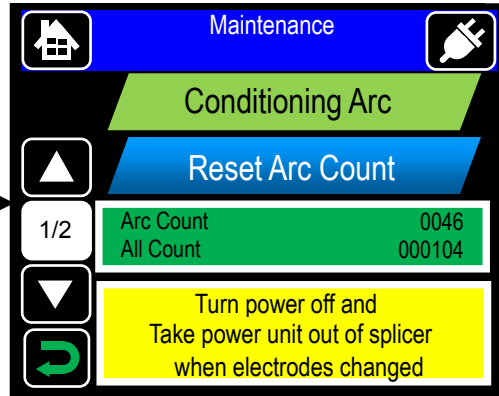

In the menu screen, touch "Maintenance" icon () to go to Maintenance screen.



Touch the item once. The icon will be highlighted in light green. Touch it once more to confirm.

Touch the "move" ( , ) to advance to the next page.

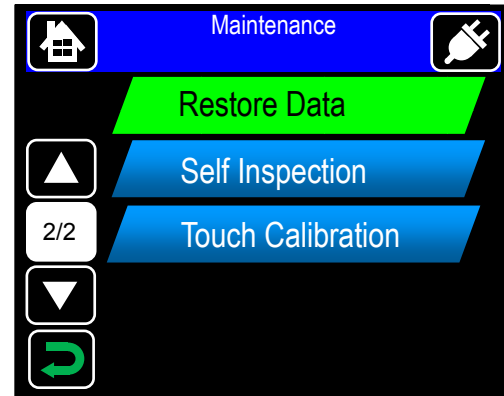

Page	Maintenance
1/2	<Conditioning Arc>
	After the electrodes are replaced, this function is used to condition a new electrode. The number of conditioning arc is preset. Arc Count is automatically reset after conditioning arc is performed.
	<Reset Arc Count>
	Arc Count can be reset, while All Count cannot.
2/2	<Restore Data>
	All parameters except Arc Count and All Count are returned to the factory setting.
	<Self Inspection>
	The circuit board, optical unit, motors and heat shrink ovens are automatically inspected.
	<Touch Calibration>
	Perform touch calibration when icons and items could not be selected correctly with touching operation.

Splice data storage function

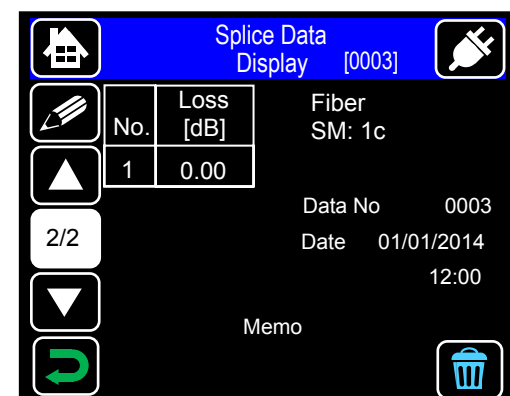
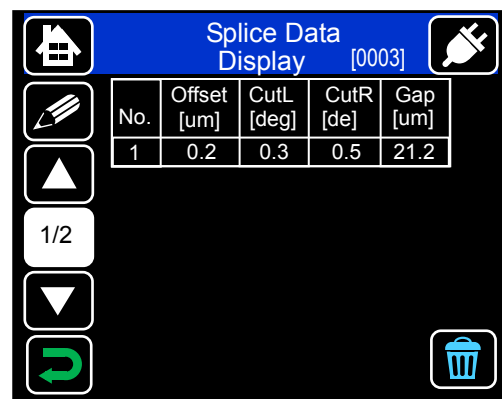
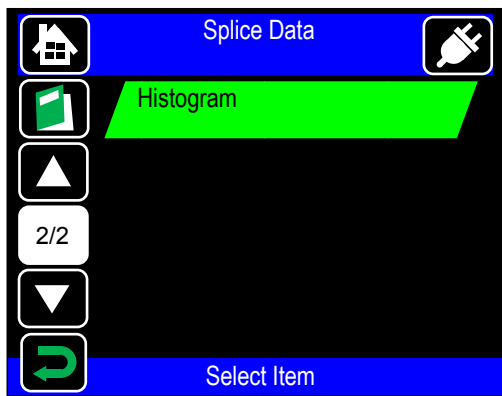
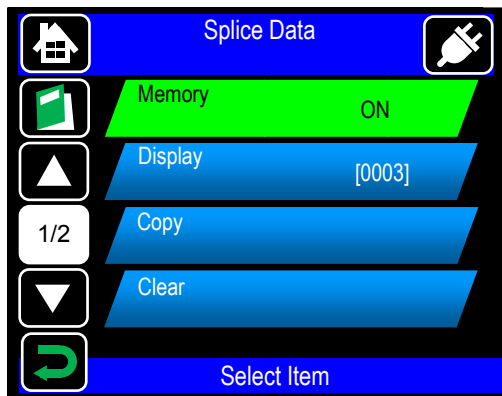

Touch the “Splice Data” icon () on the menu screen to go to DATA screen. Please set "Memory" to ON before splicing if you want to save splice data.

To display stored splice data, select “Display”. Enter the memory location you would like to view.

If "Copy" is selected, saved data is copied to a microSD card in CSV format.

In "Histogram", the histogram of estimated losses and cleave angle can be displayed based on the data that has been saved.

Description of data

- ◆ Offset: Inspected offset of diameter axis.
- ◆ CutL: Inspected cleave angle of left fiber.
- ◆ CutR: Inspected cleave angle of right fiber.
- ◆ Gap: Inspected arc gap
- ◆ Irregular: Inspected irregularity in fiber end position for left or right fibers.
- ◆ Loss: Estimated losses

If the dust box icon () is touched, the referred data is deleted.

Add a memo by touching “MEMO” ().

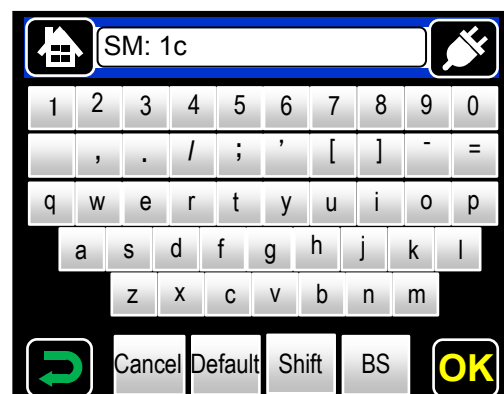

USB connection function

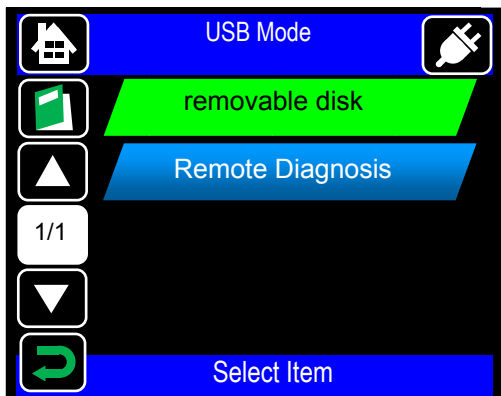

Touch the USB icon () in the menu screen to go to the USB mode screen. The following functions can be used by connecting the TYPE-201e-VS/M4 to a PC via USB cable, and selecting each item.

<Removable disk> :

While a microSD card is inserted in the microSD card slot, data stored in the microSD card can be read and written from the PC.

<Remote Diagnosis> :

Select this item if you would like to have remote diagnosis service for the TYPE-201e-VS/M4.

Software download via internet

Access the URL below to get a maintenance application for your PC. You can upgrade your splicer to the latest software via internet using the application. For further information, read the maintenance application user manual which can be downloaded from the web page below.

<http://www.rim-plus.sei.co.jp/>

Login function

By inputting the pass code, expanded functions for an administrator can be used. Please refer to "Administrator menu operation instructions" for further details.



Help function

The TYPE-201e-VS/M4 has a function to show user training videos as to fiber preparation, daily maintenance and cleaning. It is possible to play back and pause, which enables an operator to go over operating procedures.



Touch the "Information" icon () in menu screen to go to movie screen.

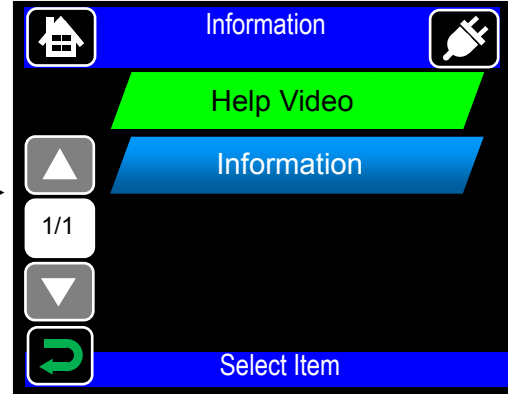

Select "Help Video".

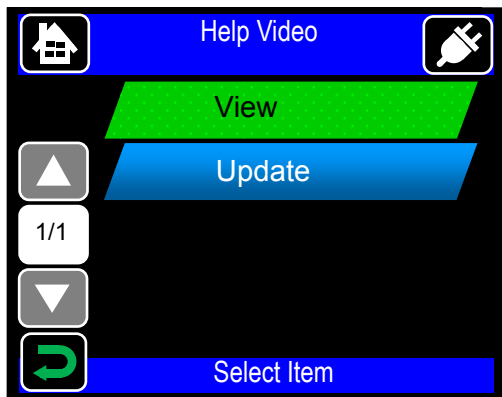

Select "View" item.

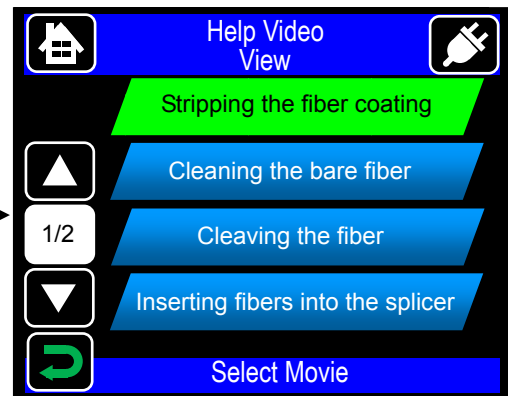

Select the video you would like to watch.

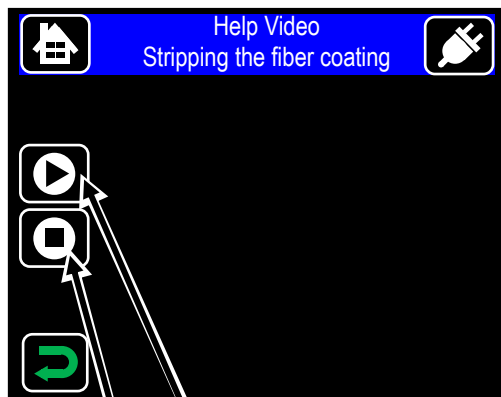

Play / Pause
Stop

5. Troubleshooting

For repair and technical support, contact maintenance service center address described in the back cover.

Arc problems

Electrodes typically need replacing after 1,500 splices for TYPE-201e-M4, 3,000 splices for TYPE-201e-VS. Some common symptoms that indicate the electrodes need replacing are:

- High or inconsistent splice losses
- Bubbles in the fibers after splicing
- Diameter faults
- Fluttering or unstable arc observed on the monitor
- Fiber burned in half
- Sizzling noise while arcing

Refer to page 3-6, "Electrode replacement procedures".

If an electrode tip touches something, it will be deformed, causing poor arcing problems. Take care of the handling of electrodes.

Fiber breaking

When the splicing process is complete, a proof test may be performed on the fibers while in the fiber chucks. If the fibers are breaking when the proof test is performed, re-do an arc test. If the arc power level is too weak, the splice may be poor, resulting in fiber breaking.

If the fibers are breaking in spite of a good arc test result, clean the V-grooves and the bare fiber pads completely. Deterioration of a jacket remover/fiber cleaver may lead to fiber breaking. Clean the jacket remover/fiber cleaver completely.

Splicer does not power up

If the fusion splicer fails to turn on when the ON key is pressed, check the following:

- Verify that the battery pack is installed in the module bay properly
- Verify that the power plug is seated properly (the power cord is connected to the AC adapter.)
- Verify that the LED of the AC adapter lights up.
- If using battery operation, ensure that the battery is fully charged.

If the splicer still does not power up after checking the above, contact our maintenance service center.

Warranty and repair service

Before requesting a repair, try to locate the problem and identify the cause by referring to “5 Troubleshooting” at page 5-1. If you ensure that your machine is really in need of a repair, contact our maintenance service center.

REGION LIMITATION

This product is sold for the use in a limited sales area (refer to the information which appears on the splicer screen) and the technical support of the product moved out of the said region may be refused or require extra charges.

Warranty period

1. About the warranty period of this product, please ask to the distributor that you purchased the product from.

Services after warranty period

After the warranty period expires, all products may be repaired for a reasonable service charge.

2. The following cases are the exception for repairing and replacing the product free of charge.
 - (1) Damage or malfunction caused by misuse, mishandling, non qualified repair, disassembly, modification, or any other irregular execution
 - (2) Damage or malfunction caused by drop, fall or any other faulty treatment such as to be explained in precautions on this manual.
 - (3) Damage or malfunction caused by actions that are beyond Sumitomo's control including for example, fire, water flood, earthquake, lightening or similar disaster, or any other accident.
 - (4) Damage or malfunction caused by the use of Product in conjunction with accessories, products, or consumables not specified or approved by Sumitomo.
 - (5) Replacement of consumables
 - (6) Travel expense that is charged if a trip for repair is requested by the customer.
 - (7) Damage or malfunction caused by use of batteries and battery chargers not specified or approved by Sumitomo.
 - (8) Products founds corroded due to exposure to water or dew condensation, or cracked or deformed circuit board.
3. The customer shall bear the cost of returning the product to Sumitomo.

Error message list

Please contact maintenance service center when it is not recovered if you take the measures below.

Error message	Countermeasure
The fibers are not placed correctly into the V-groove.	Place the fiber correctly into the V-groove again. >Refer to page 2-14. There is a possibility that dust or dirt is on the V-groove and the fiber clamp when the error occurs repeatedly. Please execute the cleaning. >Refer to page 3-2.
The splicer failed to adjust the LED brightness.	Please clean the microscope lens and LED. >Refer to page 3-2 and 3-3.
The splicer is unable to start splicing because the hood is open.	Please close the hood. Very high voltage is generated with the splicing. The splicer never starts splicing with opening hood for safety.
The splicer could not detect the fiber.	Please place the fiber correctly into the V-groove again. >Refer to page 2-14.
The splicer failed to inspect the right and left fibers.	Place the fiber correctly into the V-groove again. >Refer to page 2-14. Please cleave the fibers again. >Refer to page 2-12 and 2-13.
The offset of the fiber exceeds the allowable limit.	Place the fiber correctly into the V-groove again. >Refer to page 2-14.
The cleave angle of the fiber exceeds the allowable limit.	Please execute the cleaning. >Refer to page 3-2. Please cleave the fibers again. >Refer to page 2-12 and 2-13.
A lip is observed on the right and left fiber ends.	If the error occurs repeatedly, the cleaver blade might be deteriorated. Change the blade position or replace the blade. For further information, refer to the operation manual of the cleaver.
A chip is observed on the fiber end.	
The splicer failed to splice the fibers.	Please adjust arc power level by performing >Refer to page 2-15 to 2-17.

[TYPE-201e-VS/M4 specifications]

Item		VS	M4
Optical fiber requirement	Material	Silica glass	
	Profile types	SMF (ITU-T G.652), MMF (ITU-T G.651) DSF (ITU-T G.653), NZDSF (ITU-T G.655) BIF (ITU-T G.657)	
	Cable types	Drop cable (2.0mm×3.1 or 2.6mm) Indoor cable (2.0mm×1.6mm)	
	Fiber diameter	125μm	
	Fiber coating diameter	250μm, 500μm, 900μm	Single fiber coating dia: 250μm, 500μm, 900μm Ribbon fiber thickness: 280-400μm
	Cleave length ^{*1}	5~10mm	10mm
	Fiber count ^{*1}	1	1, 2, 4
Size and weight	Size (main body) ^{*2}	110W×140D×76H (mm)	
	Weight	Approx. 770g(with BU-12S) Approx. 860g(with BU-12L)	
	Monitor	3.5 inch touch screen color LCD display	
Standard performance	Typical splice loss ^{*3}	SMF: 0.05dB, MMF: 0.03dB, DSF: 0.08dB, NZDSF: 0.08dB	
	Typical splice time ^{*3}	Approx. 11 sec	Approx. 14 sec
	Typical heating time ^{*4}	Approx. 30 sec ^{*5}	Approx. 30 sec ^{*6}
	Splicing/heating operation per fully charged battery ^{*7}	Approx. 30 (with BU-12S) Approx. 100 (with BU-12L)	
Functions	Loss estimation	Provided	
	Splice data storage	10,000 splices	
	Splice image capture	64 splices	
	Proof test ^{*8}	Proof load 1.96N (200gf)~2.09N (213gf)	
	Auto start	Splice / Heating	
	Arc test function	Provided	
	Automatic arc compensation	Provided	
	Automatic fiber count detection	---	Provided
	Communication interface	USB 2.0 mini-B type	
	Recording medium	microSD/microSDHC memory card	
	Help videos	Provided	
	Software update	Internet	
	Internet remote diagnosis	Provided	
Programs	Splice programs	Max. 200	
	Heating programs	Max. 100	
Power supply	AC operation	With ADC-1340A Input: AC 100-240V 50/60Hz	
	DC operation	Input: DC 10-15V, 4.5A	
	Battery operation	11.1V (1530/3060mAh) with BU-12S/12L	
Environmental conditions	Operation temperature ^{*9}	-10 °C ~ +50 °C	
	Storage temperature ^{*9 *10}	-40 °C ~ +80 °C	
	Altitude	Max. 3,660m	
	Windproof	Max. 15m/s	
	Water & Dust resistance	Equivalent to IP52 ^{*11}	
Shock resistance	Drop from 76cm on bottom surface ^{*12}		
Electrode life ^{*13}	3,000	1,500	

- *1 The applicable fiber protection sleeves vary depending on the cleave length.
- *2 The protrusion part is not included.
- *3 With Sumitomo identical fiber (in room temperature. Varies depending on the condition of fiber.)
- *4 With the AC adapter in room temperature (20°C). If the battery pack is used, the heating time varies depending on the temperature and the remaining battery capacity.
- *5 With Sumitomo fiber protection sleeve FPS-61-2.6.
- *6 With Sumitomo fiber protection sleeve FPS-5.
- *7 With a new battery pack, 1 splice cycle time (splice + protection) completes in 90 seconds, in room temperature. Splice & heat cycles may vary depending on the operating environment.
- *8 Performed on the fiber stage after splicing.
- *9 Non-condensing
- *10 The Battery pack storage temperature range: -20°C ~ +50°C (if stored for less than 1 month), -20°C ~ +40°C (if stored for less than 3 months), -20°C ~ +20°C (if stored for less than 1 year).
- *11 Dust resistance: Operates normally after 8 hours in a dust chamber containing dust of particle size 75µm or below. The test is held with the battery operation, carried out by Sumitomo, but does not guarantee that the product is free of faults or damage.
Water resistance: Operates normally after being exposed to water dripping at 3mm/min, for at least 2.5 min on each of 4 surfaces tilted at 15°. The test is held with the battery operation, carried out by Sumitomo, but does not guarantee that the product is free of faults or damage.
- *12 The machine spliced the fiber successfully after dropped from 76cm height on bottom surface at free-fall. The test is held with the battery operation, carried out by Sumitomo, but does not guarantee that the product is free of faults or damage.
- *13 Electrode life is not guaranteed. This number may vary depending on the operating environment.

Tokyo (JAPAN)
Sumitomo Electric Industries, Ltd.
(Global Business Dept.)
Akasaka Center Building, 1-3-13, Motoakasaka,
Minato-ku, Tokyo
107-8468, JAPAN
Tel: +81 (0)3 6406 2666
<http://global-sei.com/sumitomo-electric-splicers/>

London (U.K.)
Sumitomo Electric Europe Ltd.
220 Centennial Park, Centennial Avenue,
Elstree, Herts, WD6 3SL, U.K.
Tel: +44 (0)20 8953 8118
<http://www.sumielectric.com/>

North Carolina (U.S.A.)
Sumitomo Electric Lightwave Corp.
78 Alexander Drive, P.O. Box 13445,
Research Triangle park,
NC27709 U.S.A.
Toll Free No. 800 358 7378
Tel: +1 919 541 8100
<http://www.sumitomoelectric.com>

Hong Kong (China)
Sumitomo Electric Asia, Ltd.
Tel: +852 2576 0080
<http://www.seac-cn.com/>

Bangkok (Thailand)
Sumitomo Electric (Thailand) Limited
Tel: +66 (0)2 260 7231 to 5
<http://www.set-th.com/>

Singapore
**Sumitomo Electric Interconnect
Products (Singapore) Pte.,Ltd.**
Tel: +65 6261 3388
<http://www.seps.com.sg/>

Dubai (U.A.E.)
Middle East office
Tel: +971 4 701 7338

Gurgaon (India)
SEI Trading India Pvt. Ltd. (SETI)
Tel: +91 124 4577 470

Manila (Philippines)
SEI (PHILIPPINES) INCORPORATED
Tel: +63 2 811 2755 to 2756